

Kontax Stirling Engines KS90 instructions

The following instructions were provided by the manufacturer.

This document covers the following:

- [Tools required](#)
- [Parts list](#)
- [Assembly instructions](#)
- [Operating instructions](#)
- [Maintenance](#)

Contact details:

- www.stirlingengine.co.uk
- support@stirlingengine.co.uk
- Tel: 01452 905001 (UK)

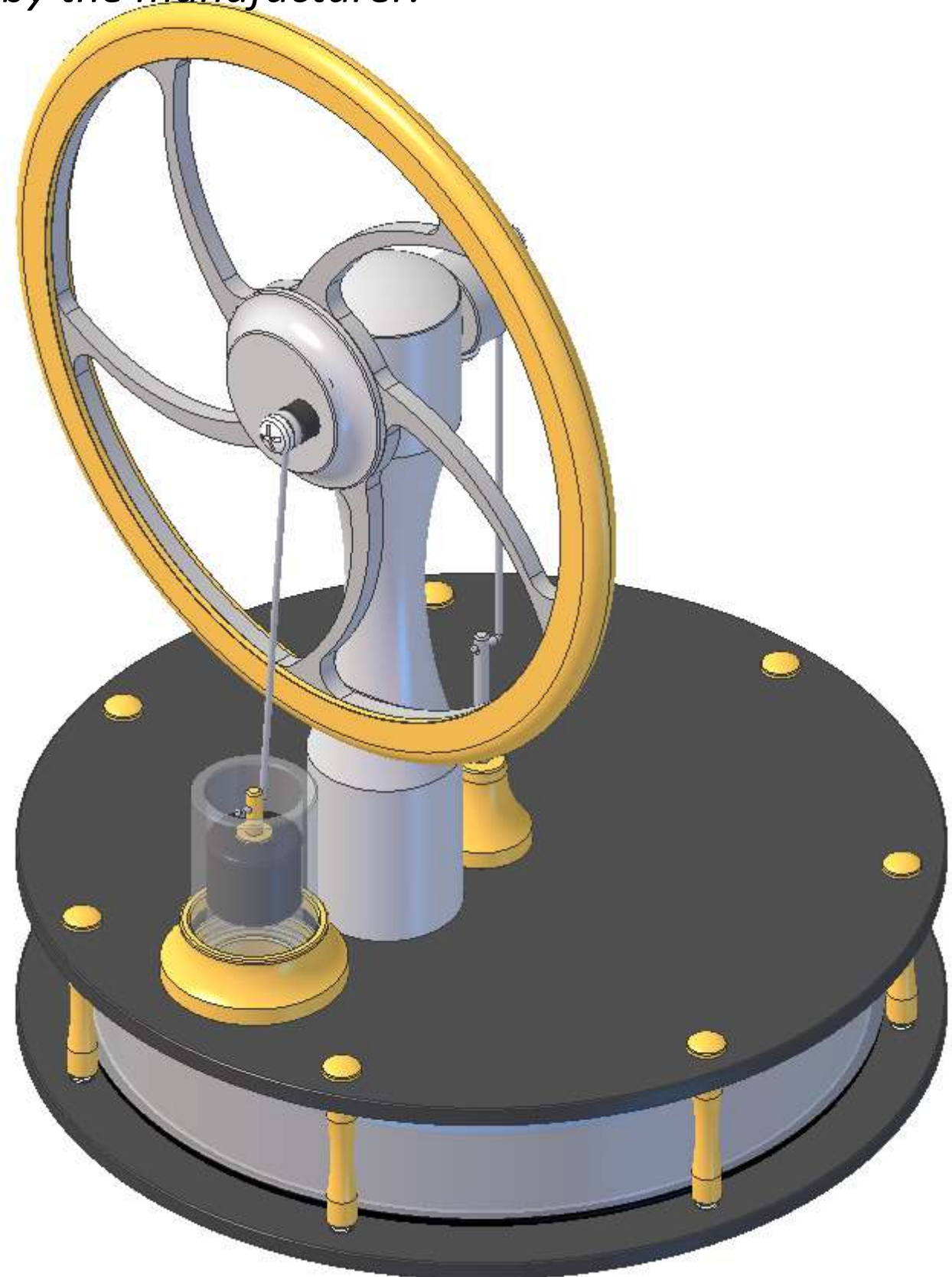

Tools you will need to assemble your KS90 Low Temperature Stirling Engine:

Cross-point screwdriver,
Flat-bladed screwdriver,
Elastic band, coffee/tea mug.

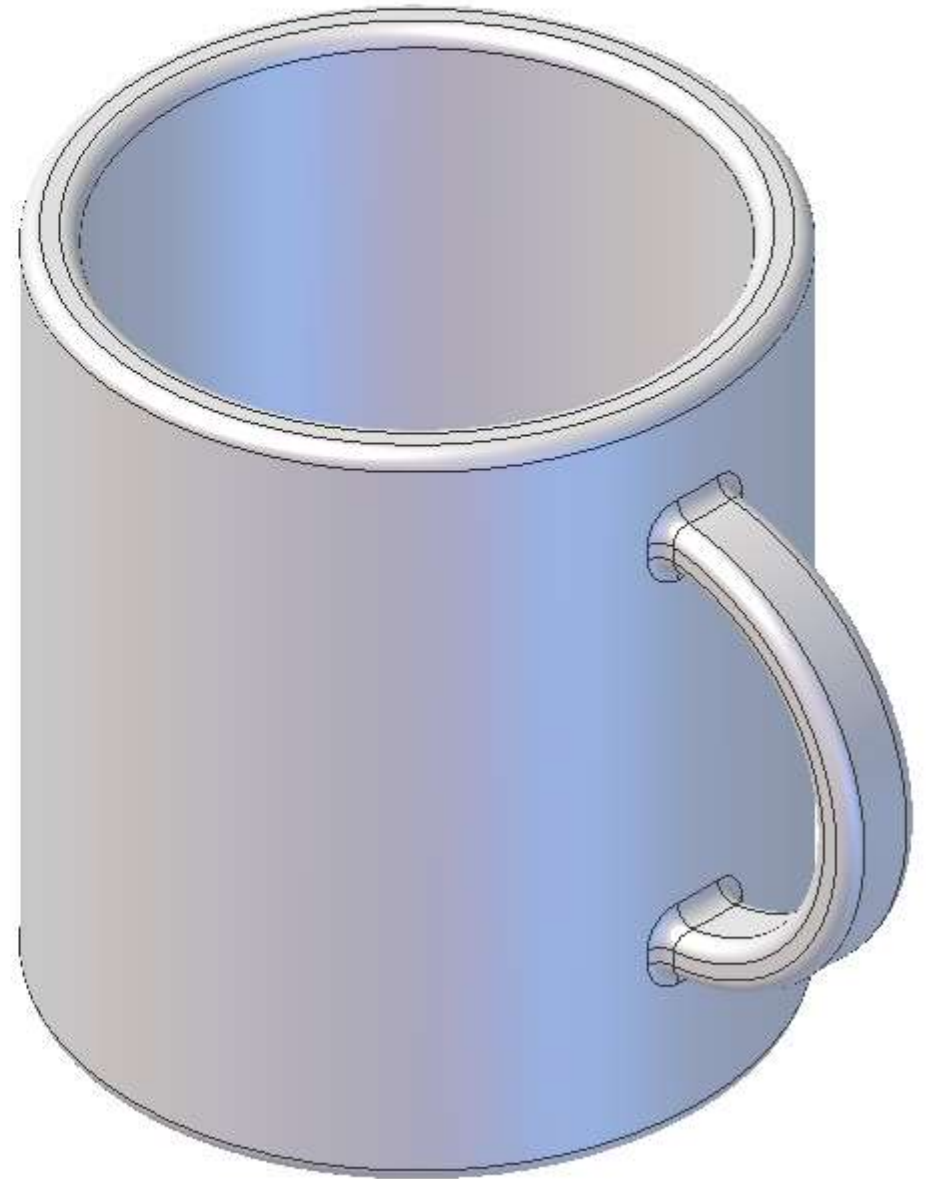
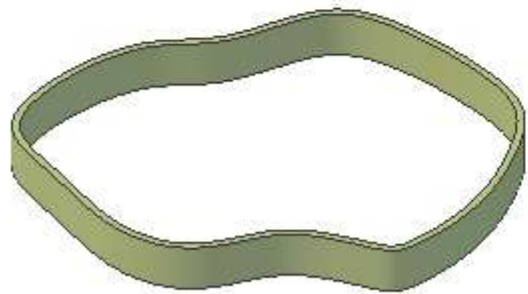

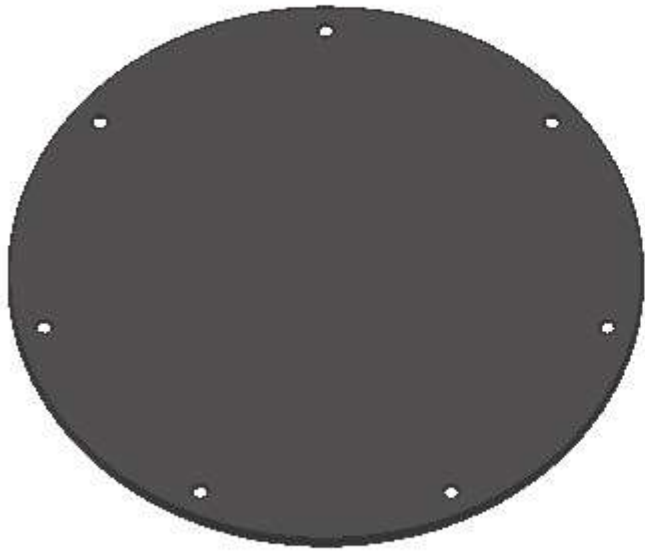

Bottom plate x1

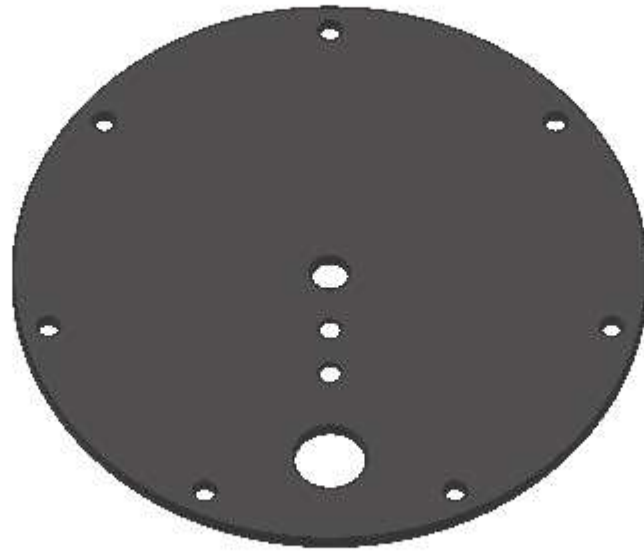

Top plate x1

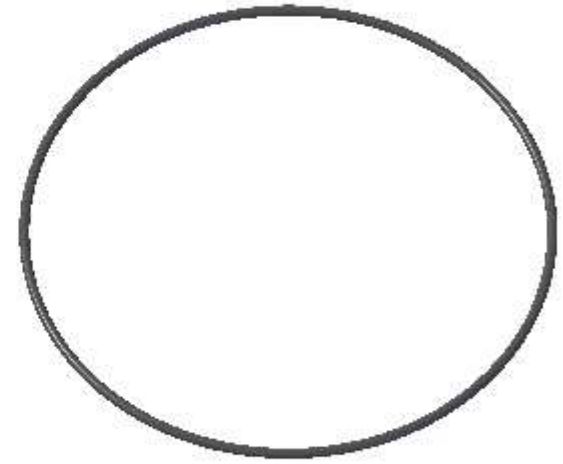

75mm O ring x2



Chamber wall x1

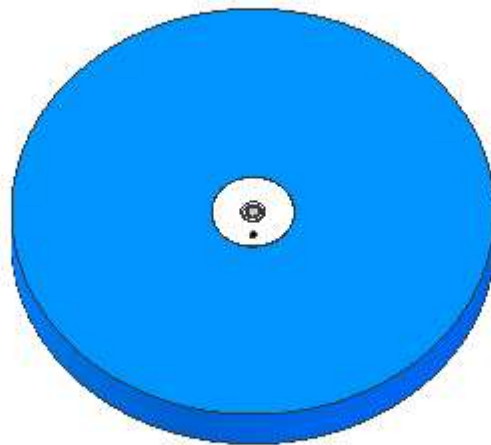

Displacer x1



Flywheel x1



Main pillar x1



Ball-race bearing x2



Piston x1

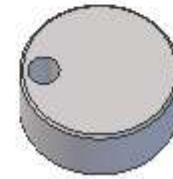

Crank x1



Cylinder x1

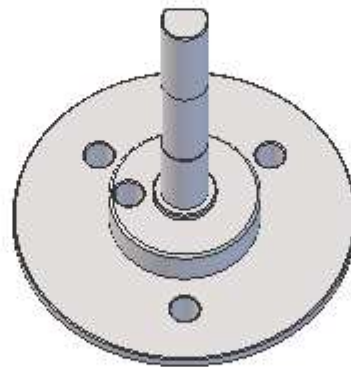

Hub/axle x1



Gland x1

Conrod x2



Note: Pre-assembled from late 2016 onwards.

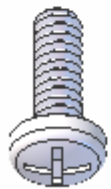

M2x6mm roundhead x2



Conrod bush x2



13mm O ring x2



M2x4mm roundhead x1

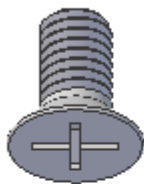

M3x6mm countersunk x2

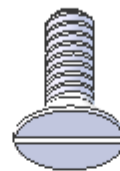

M2x6mm countersunk x7



M2x4mm countersunk x3



Gland stem x1



Chamber pillar x7



7mm O ring x1

Slide the gland onto the gland stem, hold the stem between the thumb and forefinger of your left hand and roll the gland along the side of your right hand forefinger.

As you roll it, work the gland along the whole length of the stem.

This will remove any particles of dust inside the gland.

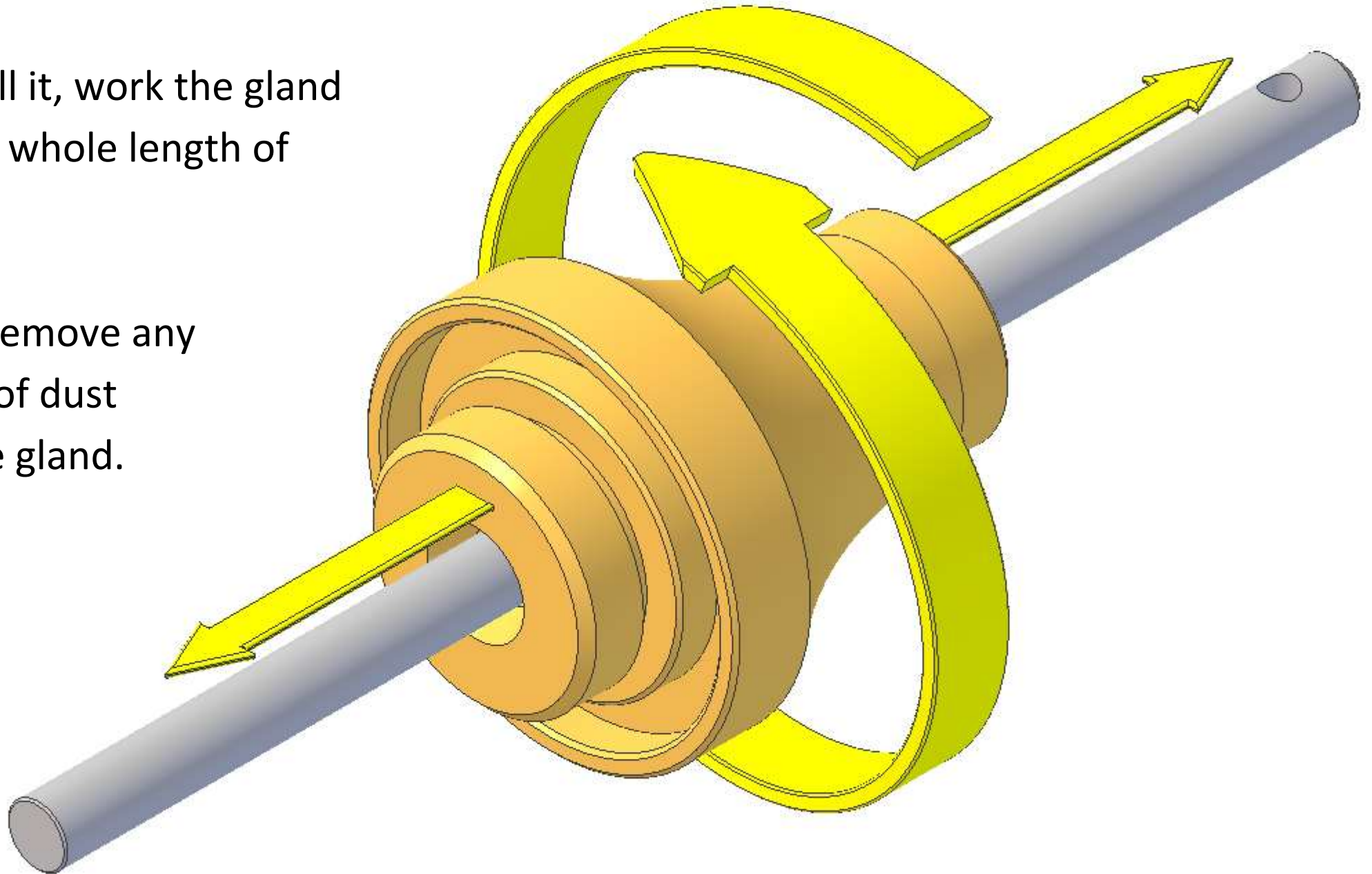

Fit one 7mm O ring into the groove in the bottom of the gland.

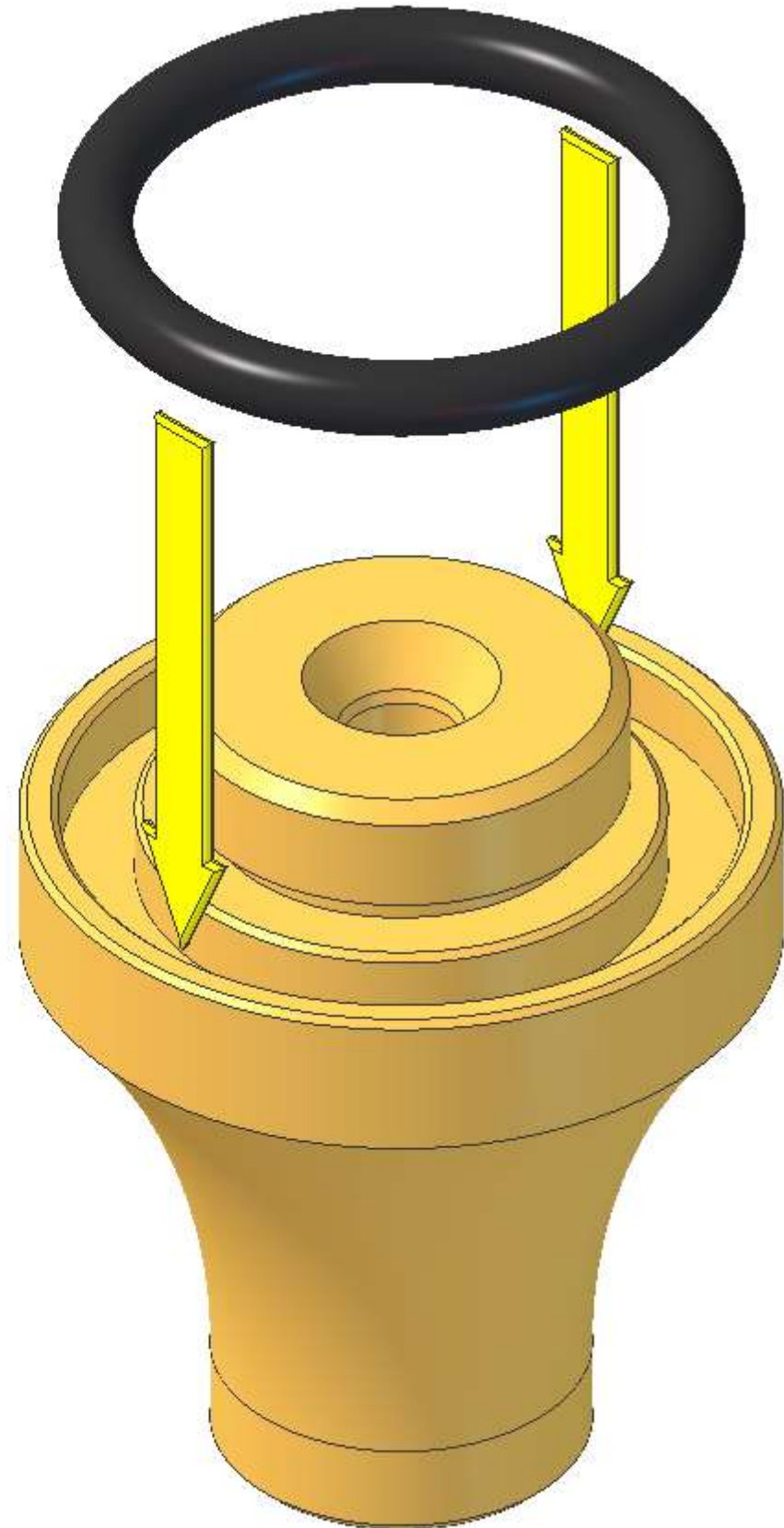

If you have solar (acrylic) or polished (stainless steel) plates you will need to remove the protective film from the top plate now. Once you have removed the film try to handle the plate by its edges, this will minimise fingerprints. Solar (acrylic) plates have protective film on both sides, polished (stainless steel) plates have protective film on one side only. Black and blue (aluminium) plates do not have protective film.

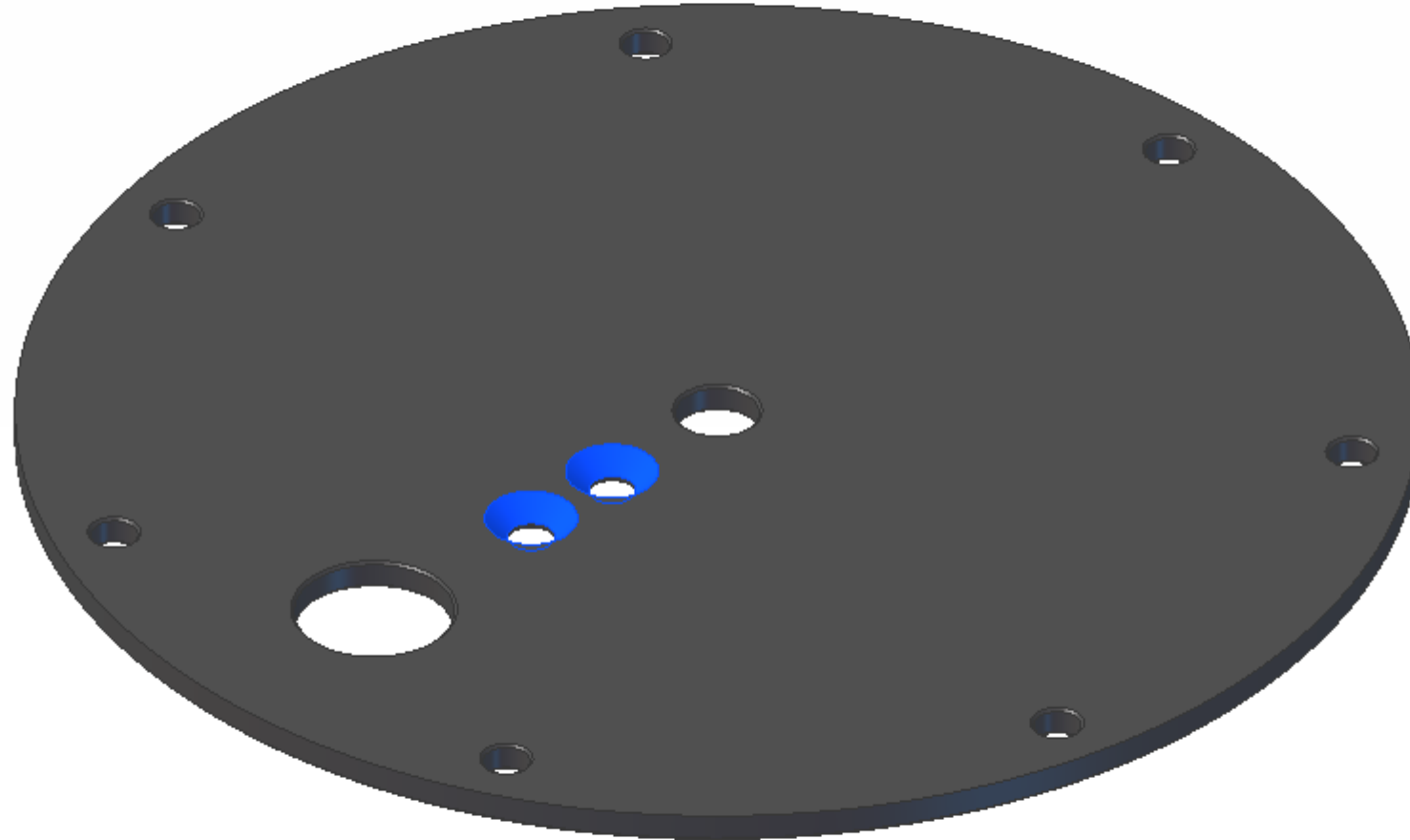

Locate the underside of the top plate.

The underside is the side with the countersinks on the two holes as shown in the diagram.

Screw the gland into the top side of the top plate and fully tighten, you might need to wrap an elastic band around it for grip. Make sure that the O ring does not become pinched or fall out of its groove. If you have trouble with the O ring falling out you can turn the plate upside down and screw the gland in from underneath.

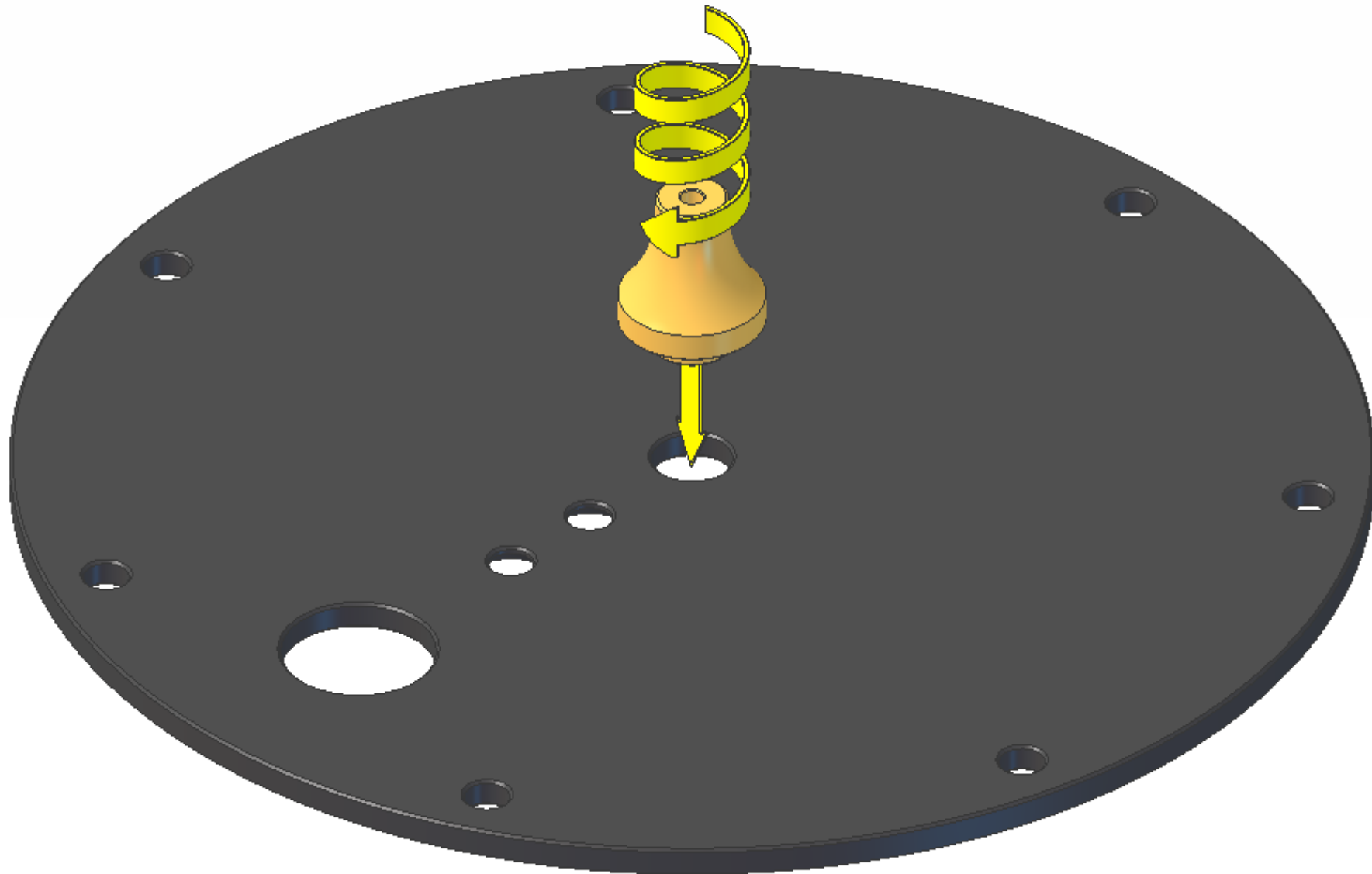

Fit one 13mm O ring into the groove in the bottom of the cylinder.

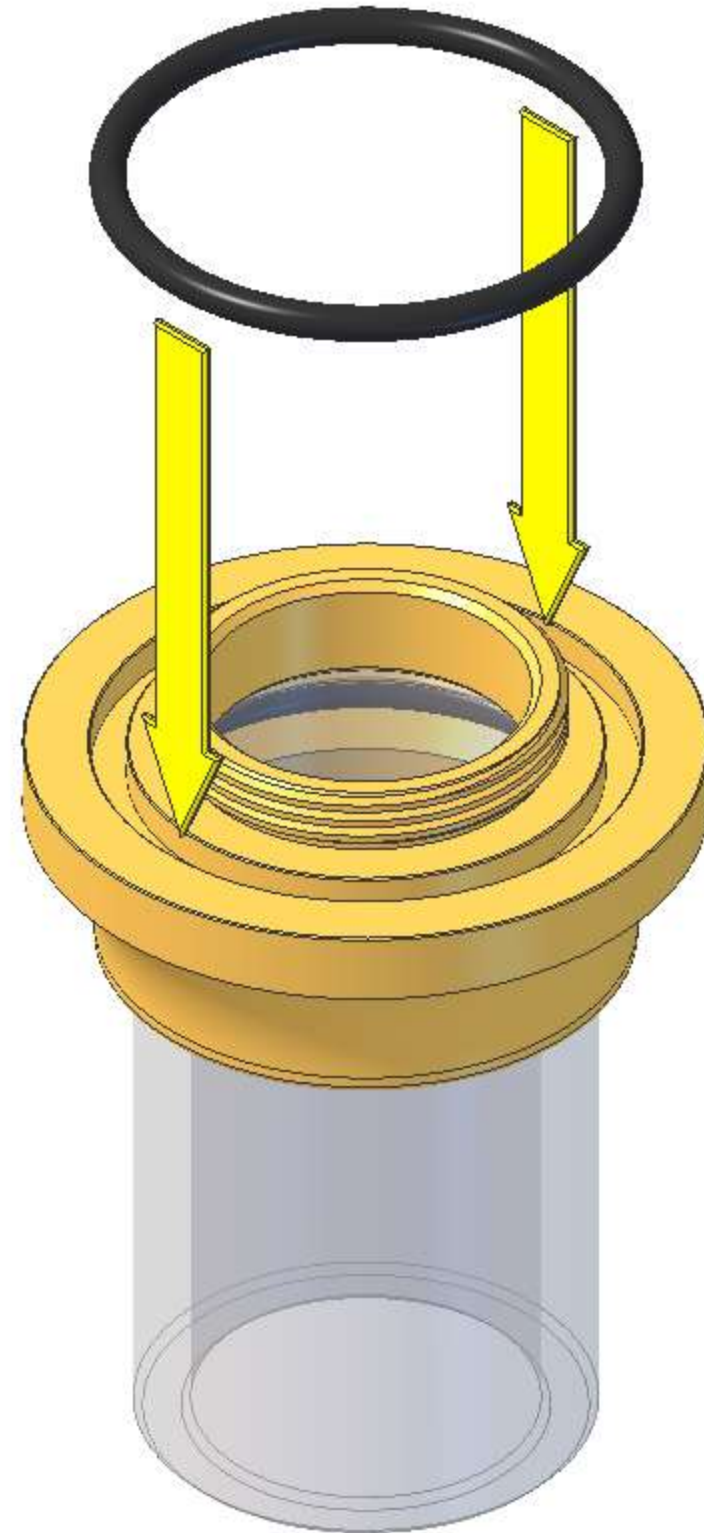

Screw the cylinder into the top side of the top plate and fully tighten, you might need to wrap an elastic band around it for grip. Make sure that the O ring does not become pinched or fall out of its groove. If you have trouble with the O ring falling out you can turn the plate upside down and screw the cylinder in from underneath.

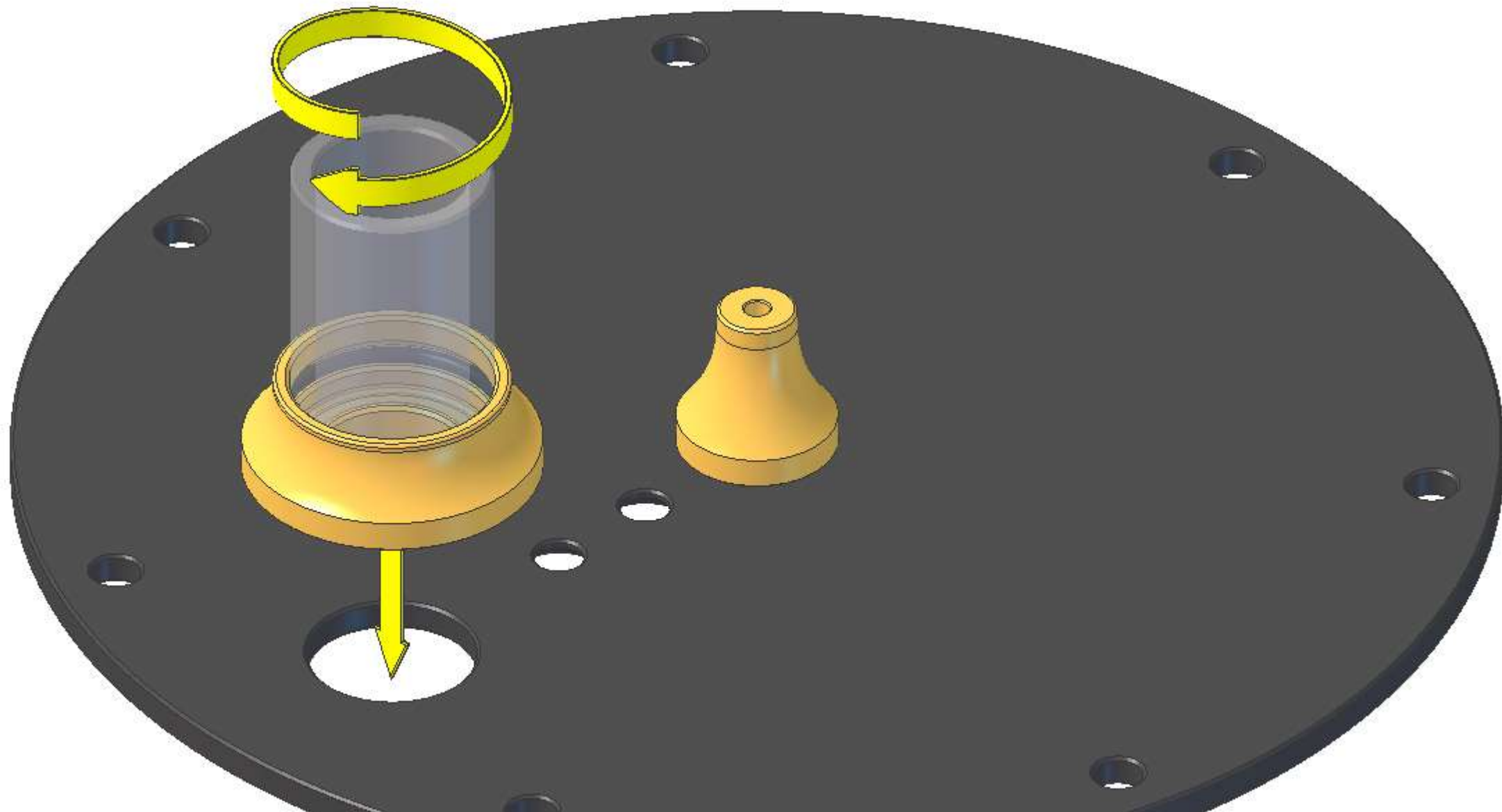

Align the hole in the main pillar as shown in the diagram and push the pillar into the hole in the packing tray. This will hold it still and upright while you perform the next few assembly stages.

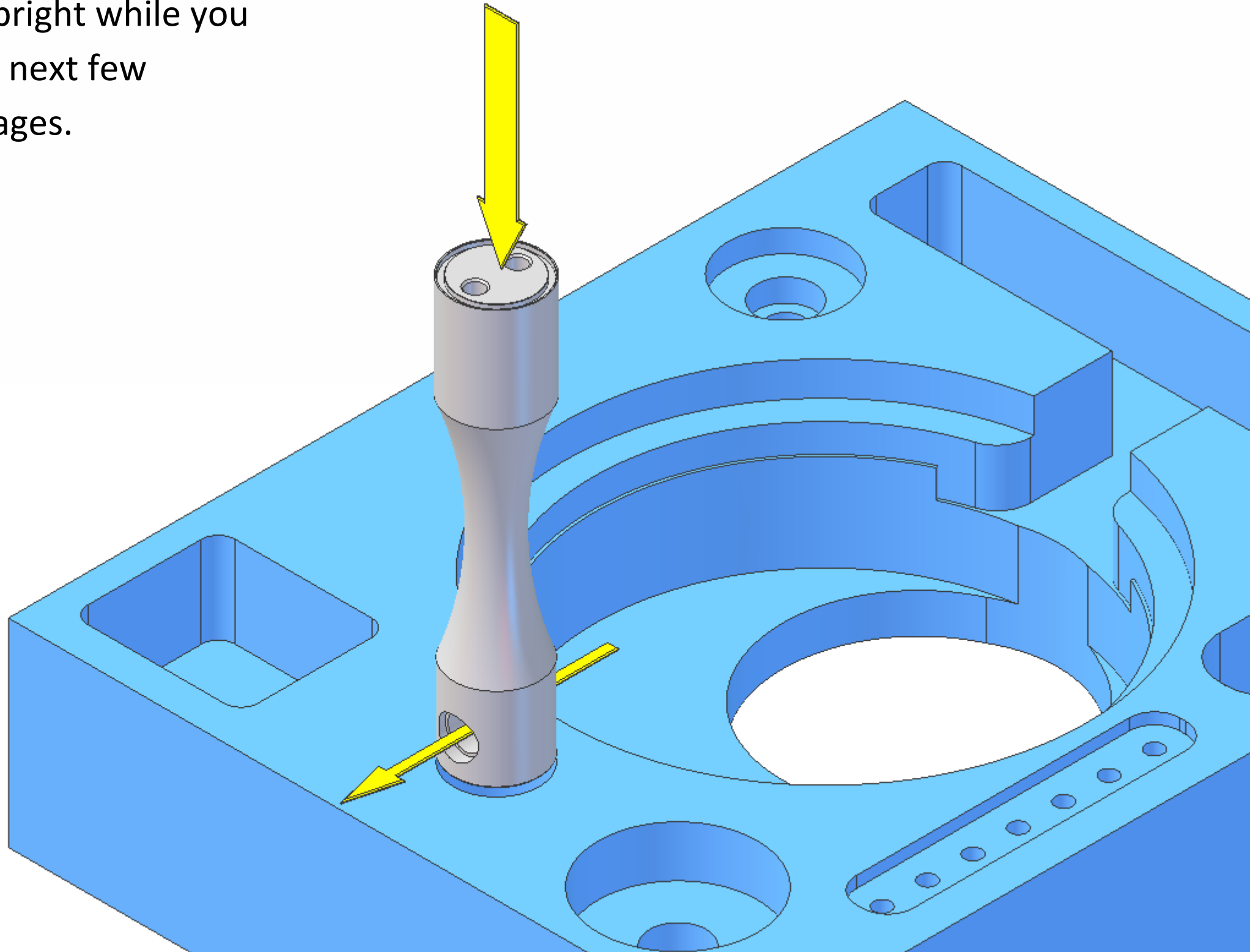

Insert one 13mm O ring into the groove in the bottom of the pillar.

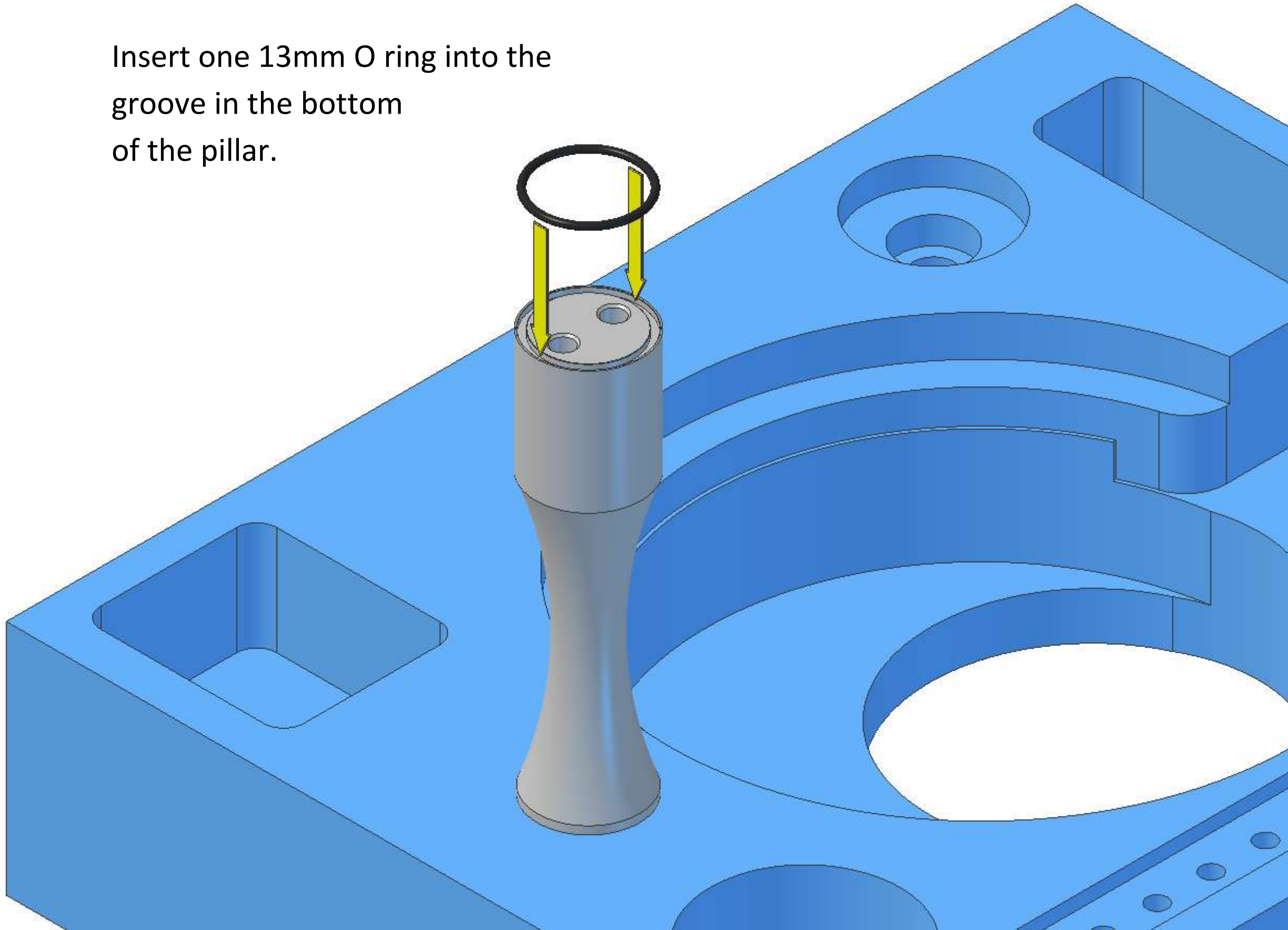

Position the top plate over the main pillar, with the underside of the plate facing upwards. Align the two countersunk holes in the plate with the two threaded holes in the main pillar and insert two M3x6mm countersunk screws a couple of turns each.

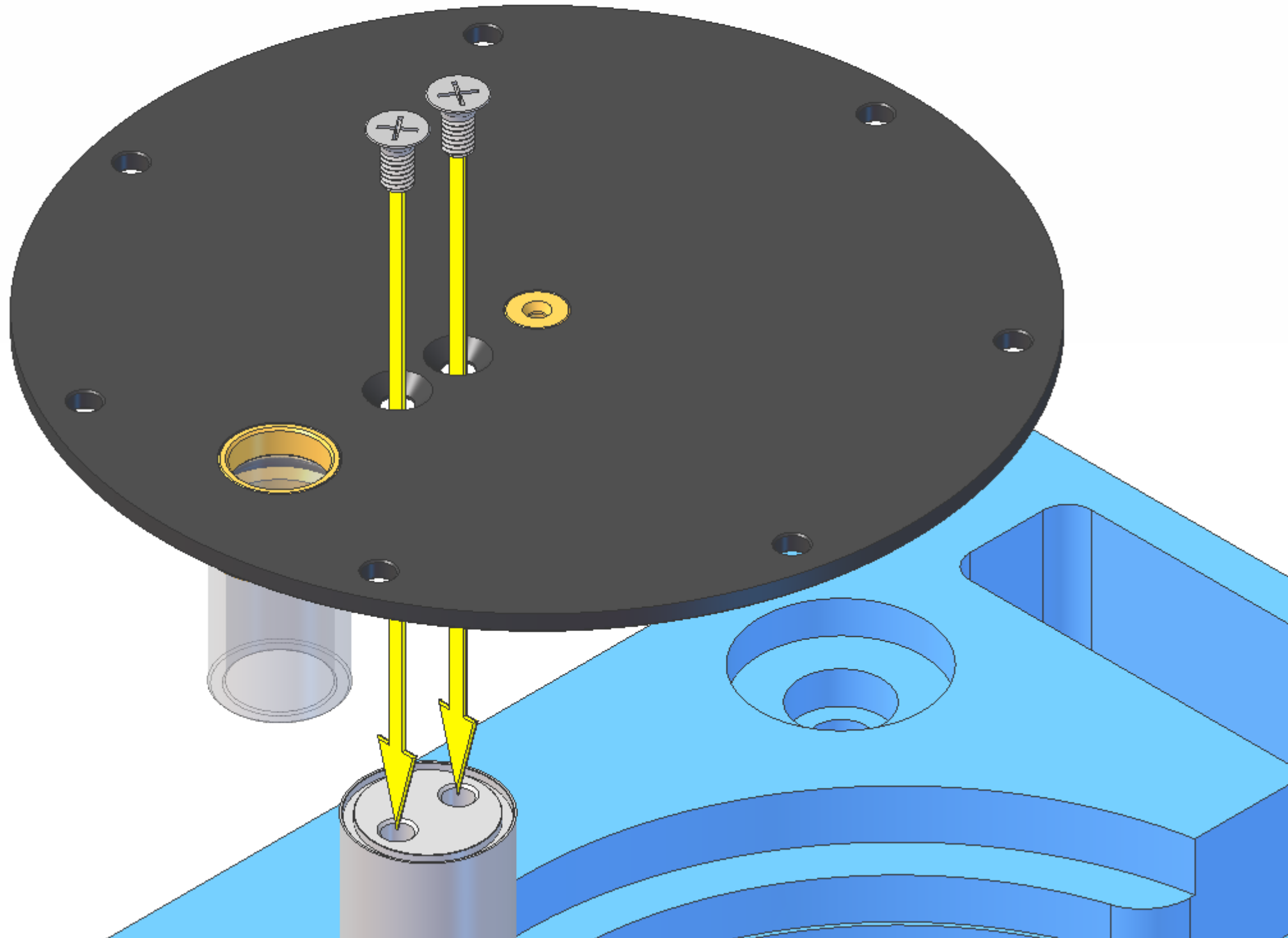

Screw the screws in until they both lightly touch the top plate, then fully tighten.

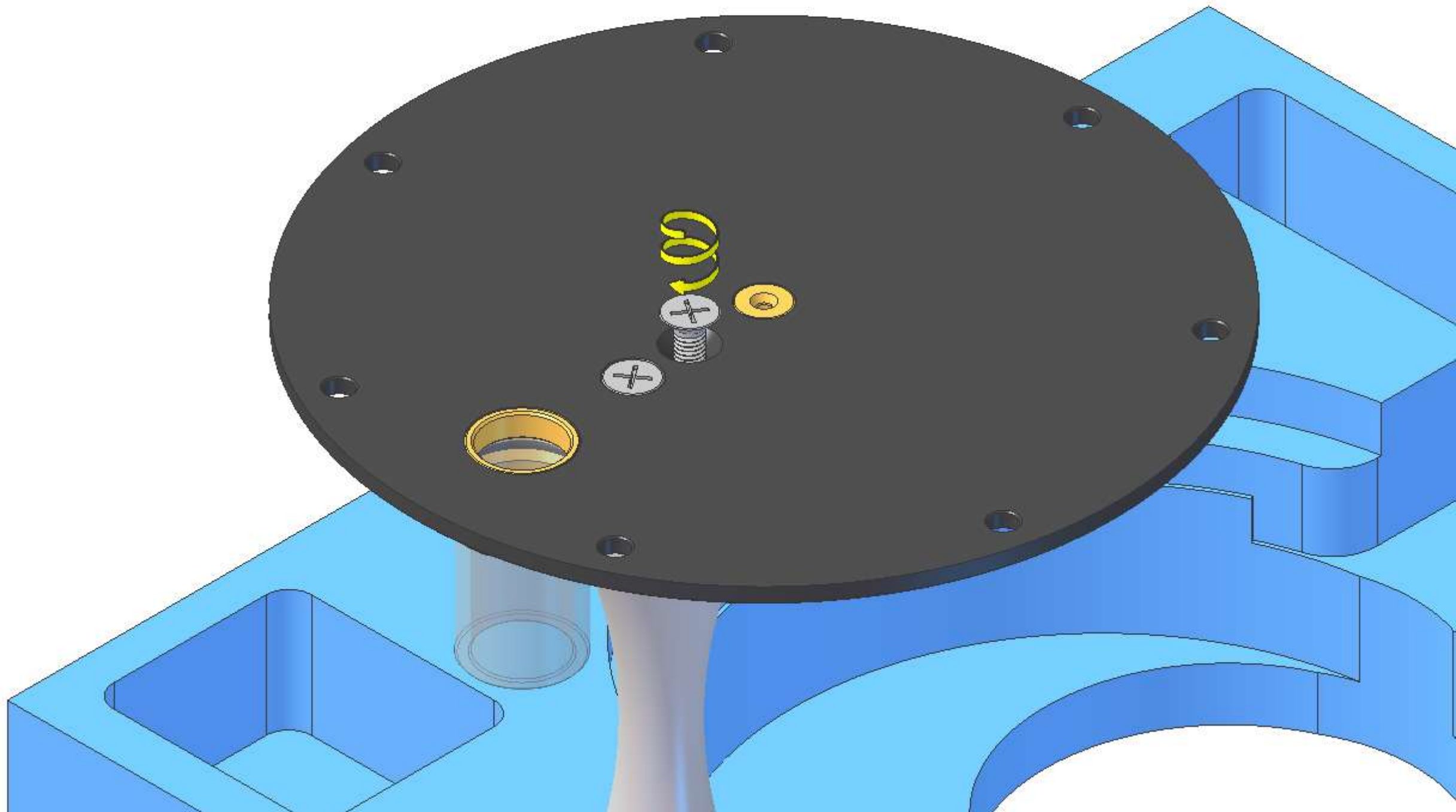

Remove the partially assembled engine from the packing tray.

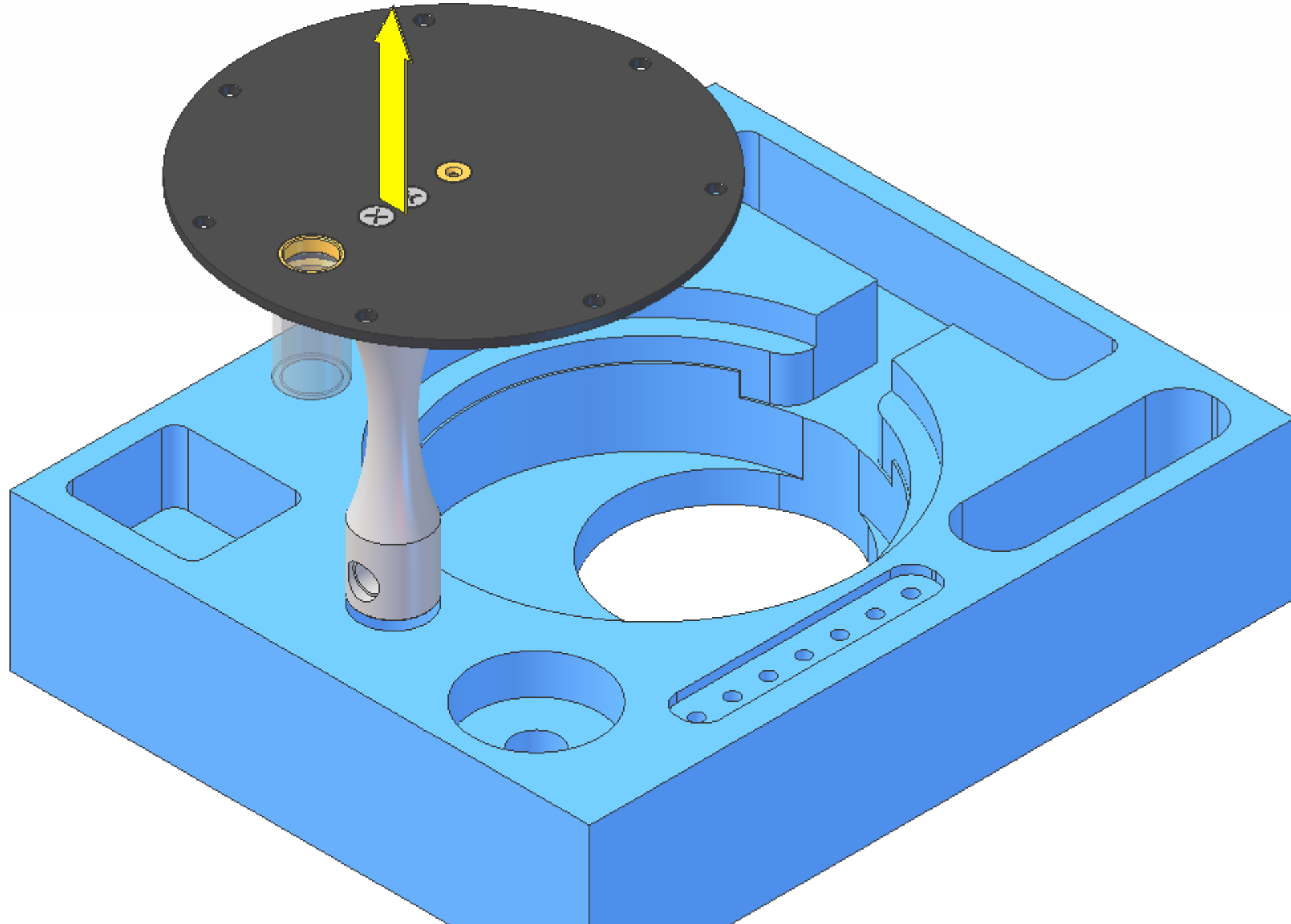

Place the partially assembled engine over the top of a coffee mug.

This will hold it still so that you can use both hands to perform the next few assembly stages.

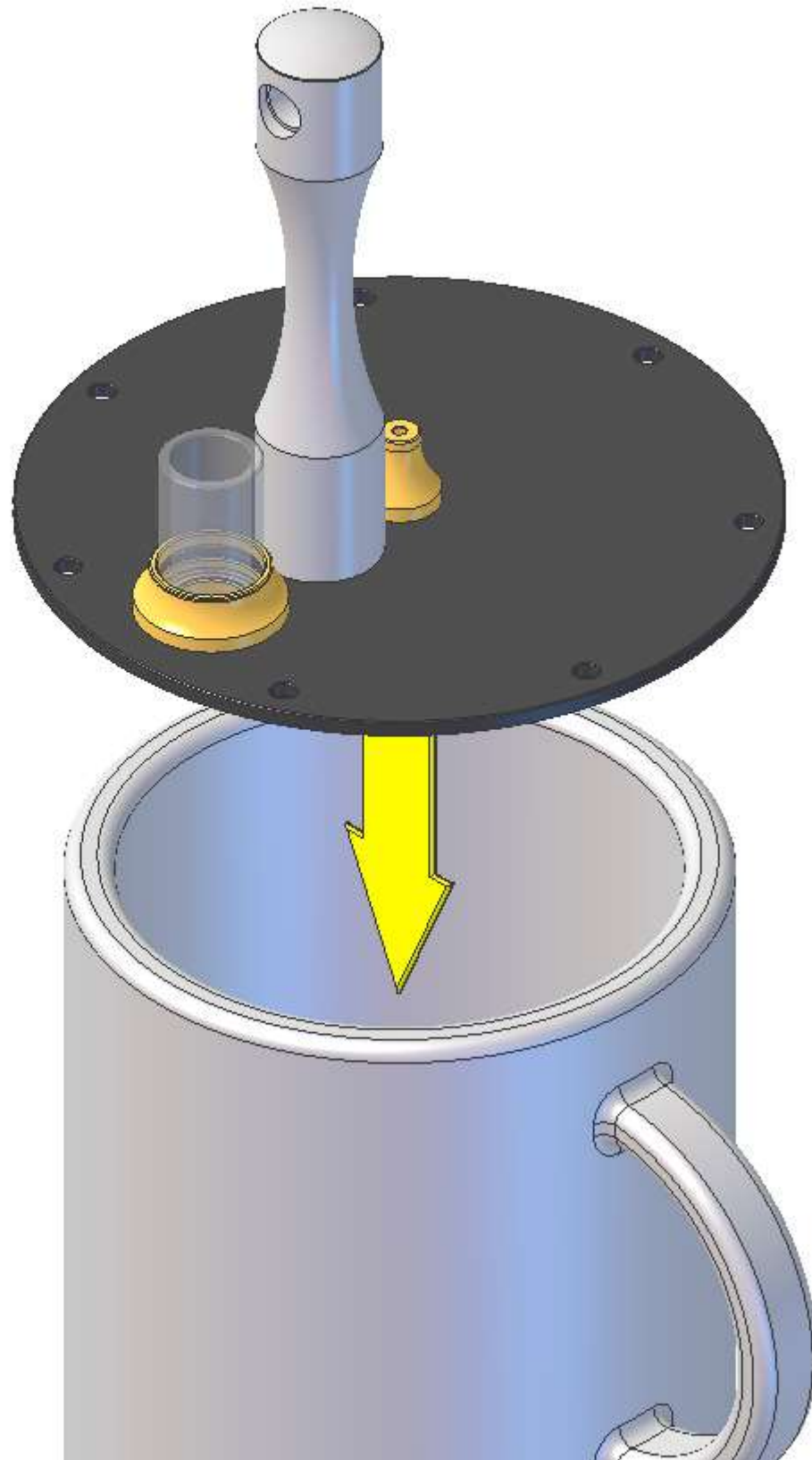

Insert seven chamber pillars into the seven small holes in the plate; they should all be an easy fit. If you have solar plates the heads of the pillars will sit below the surface, if you have polished, black or blue plates the heads will sit on the surface.

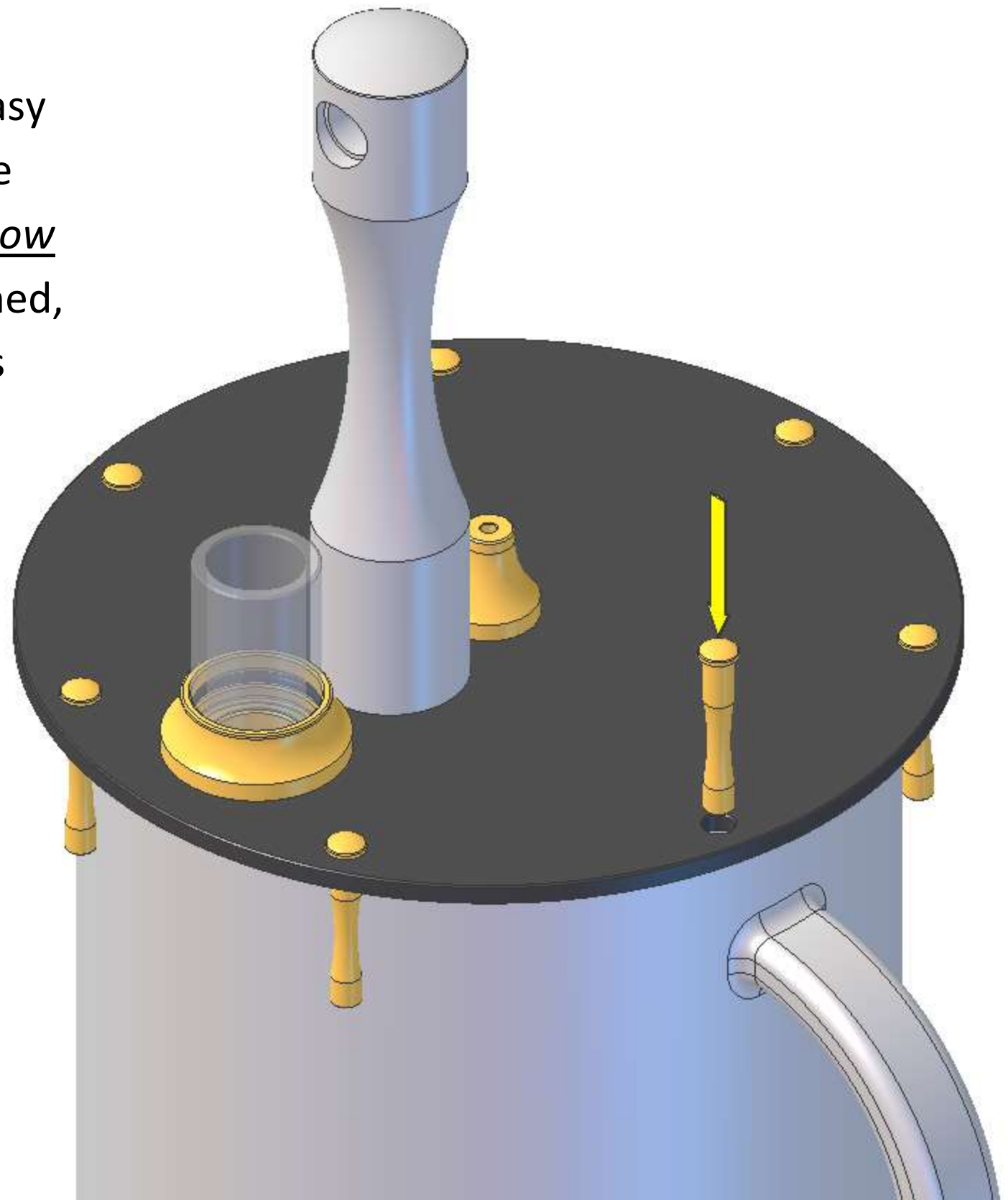

Position the packing tray over the partially assembled engine and align the hole in the bottom of the tray with the main pillar, gland and cylinder.

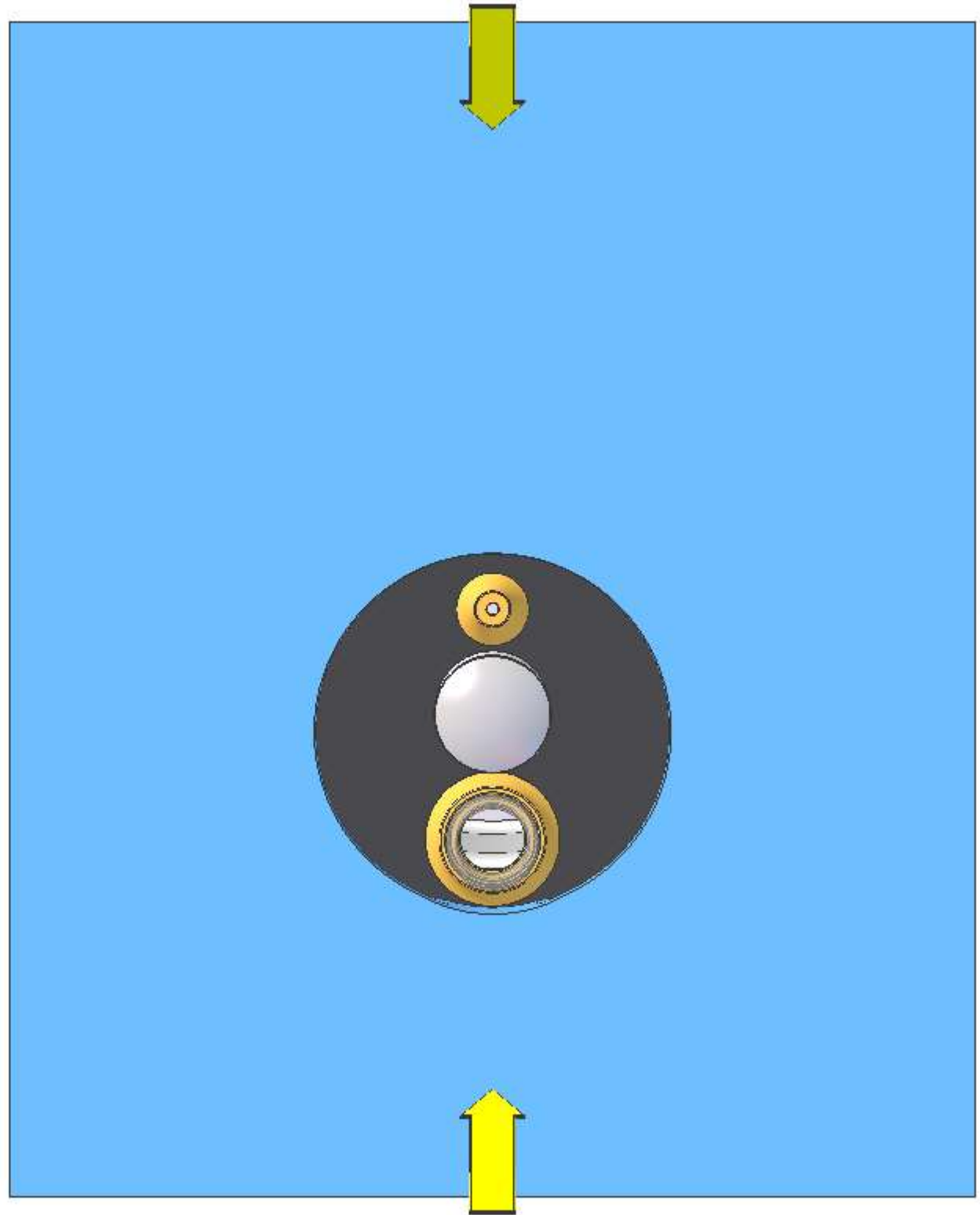

lower the tray down until it sits on top of the brass chamber pillars, the engine plate will fit inside the first step on the inside of the tray.

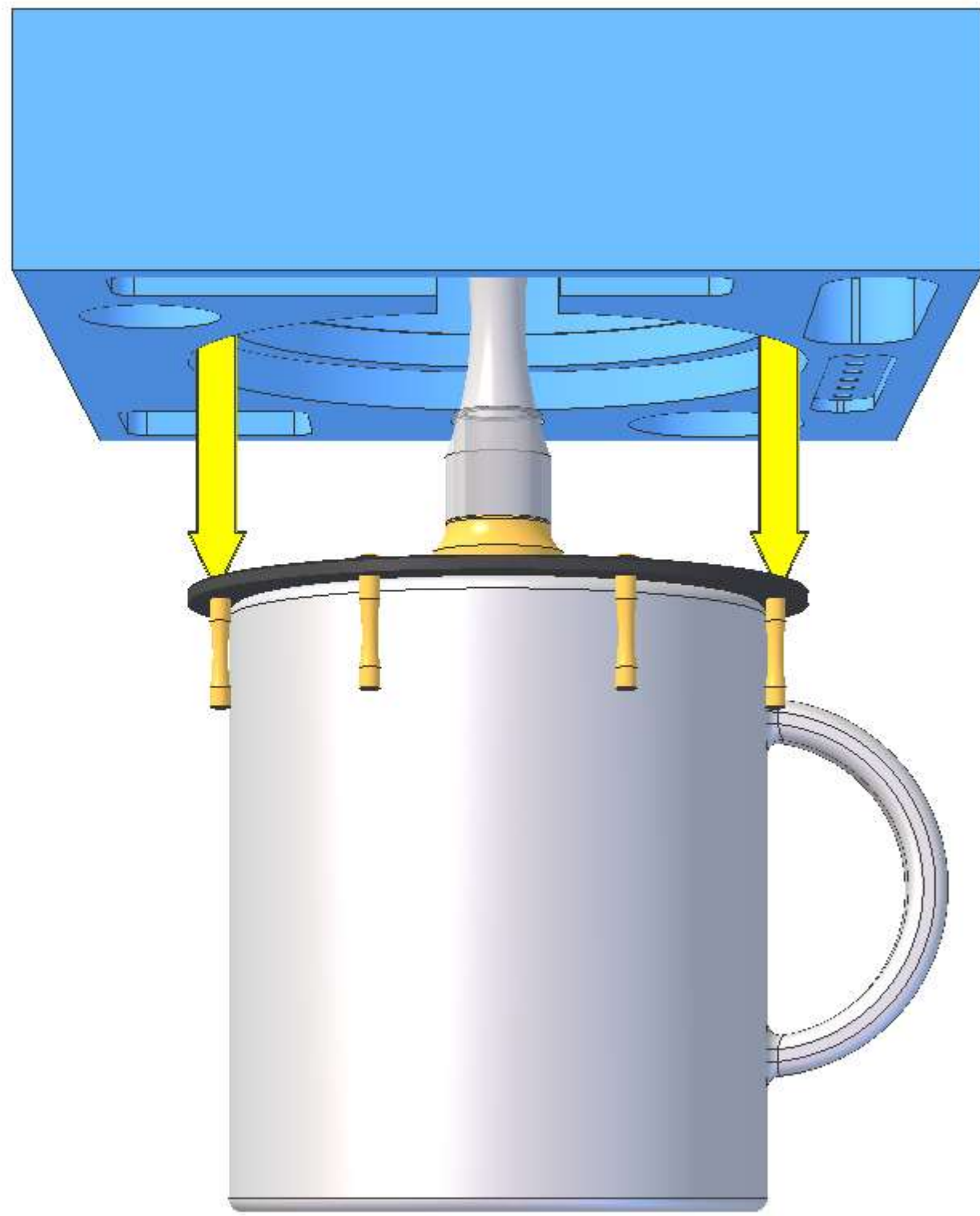

Hold the packing tray and engine firmly together so that the chamber pillars do not fall out of the top plate.

Remove from the mug, carefully turn upside down and place back on top of the mug, with the main pillar inside the mug. The packing tray will hold the chamber pillars in a vertical position while you perform the next few assembly stages.

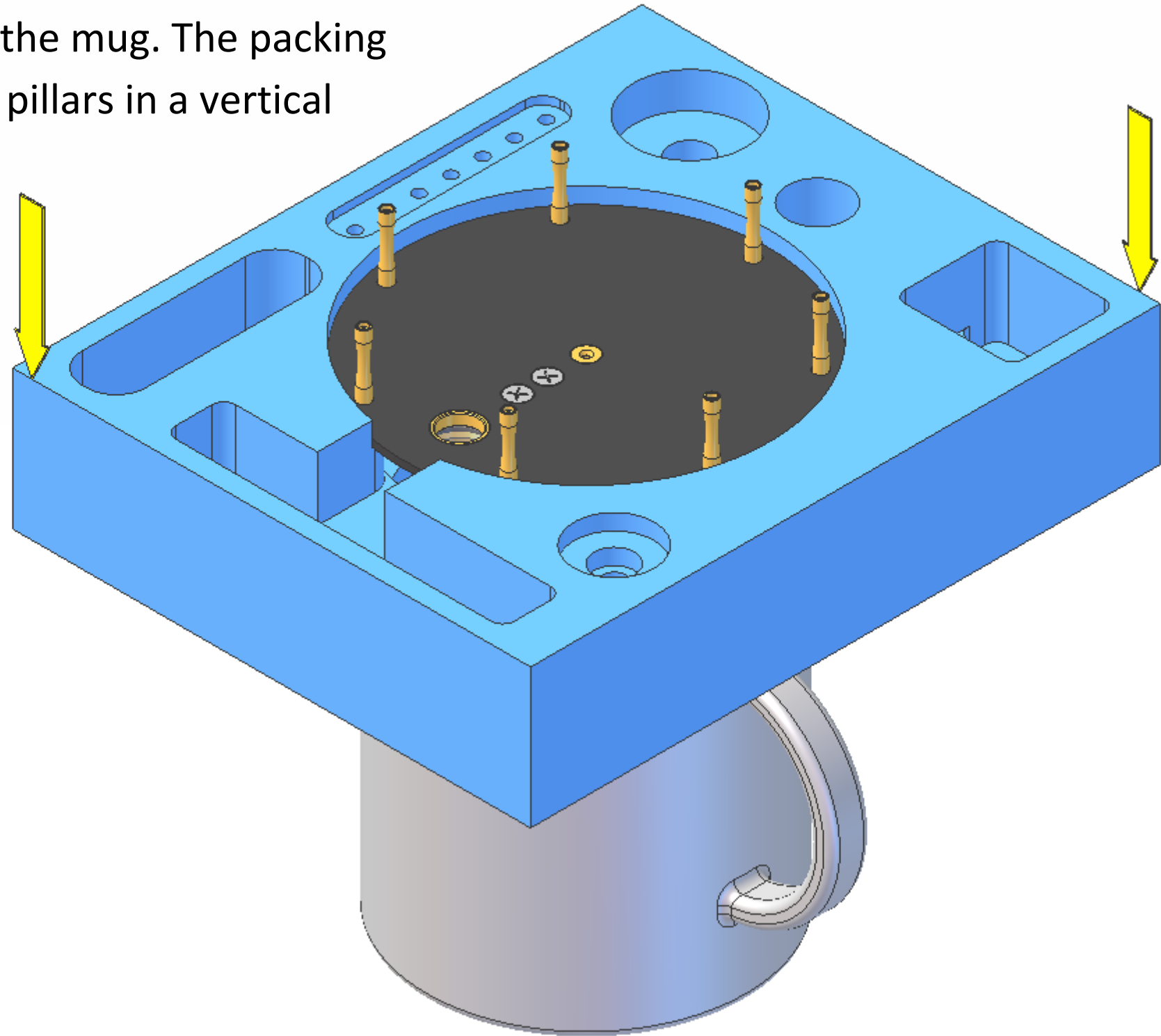

Wipe the chamber wall with a dry cloth to remove any fingerprints. Stretch one 75mm O ring over the rebate on one end.

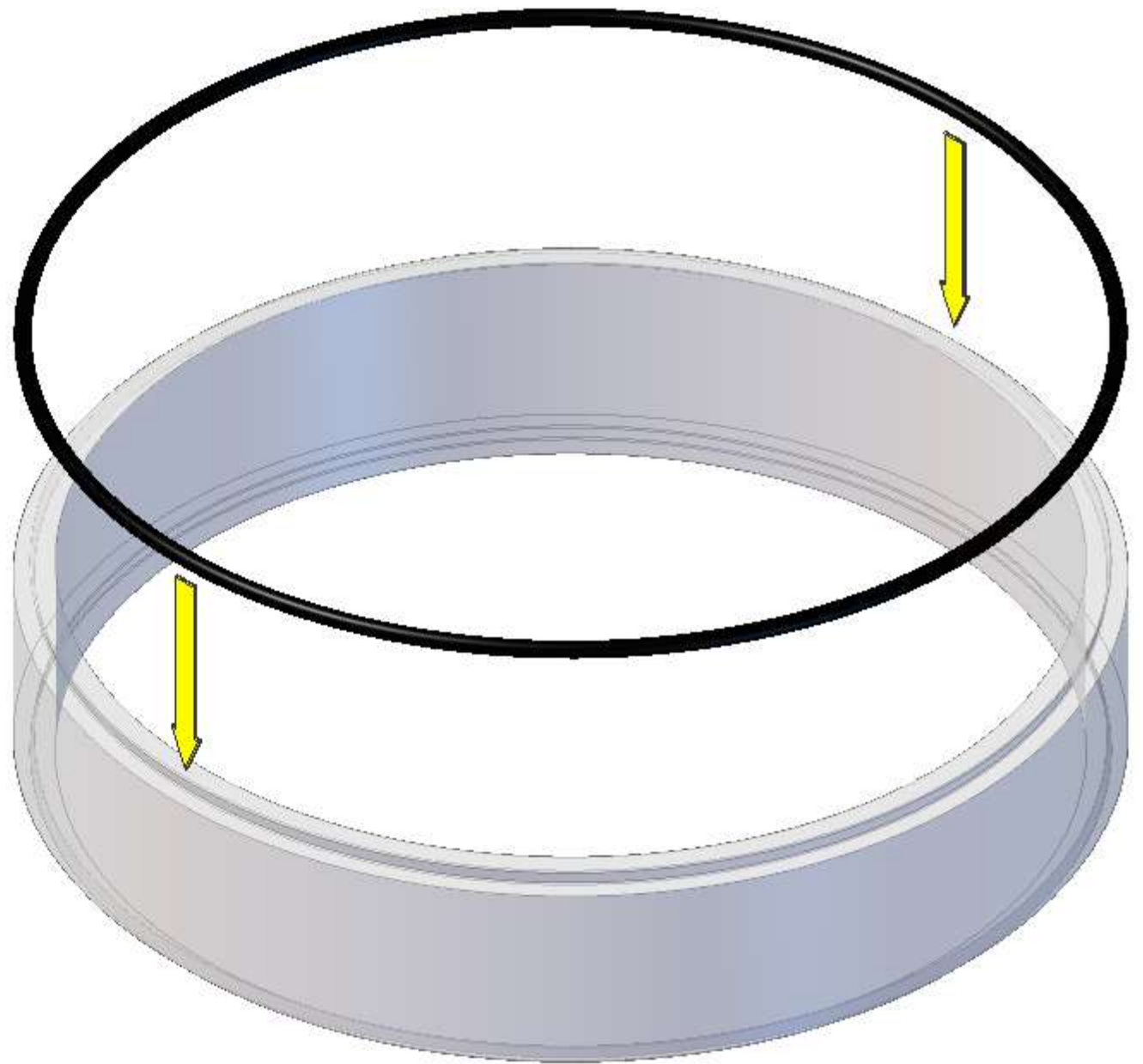

Stretch another 75mm O ring over the rebate on the other end of the chamber wall.

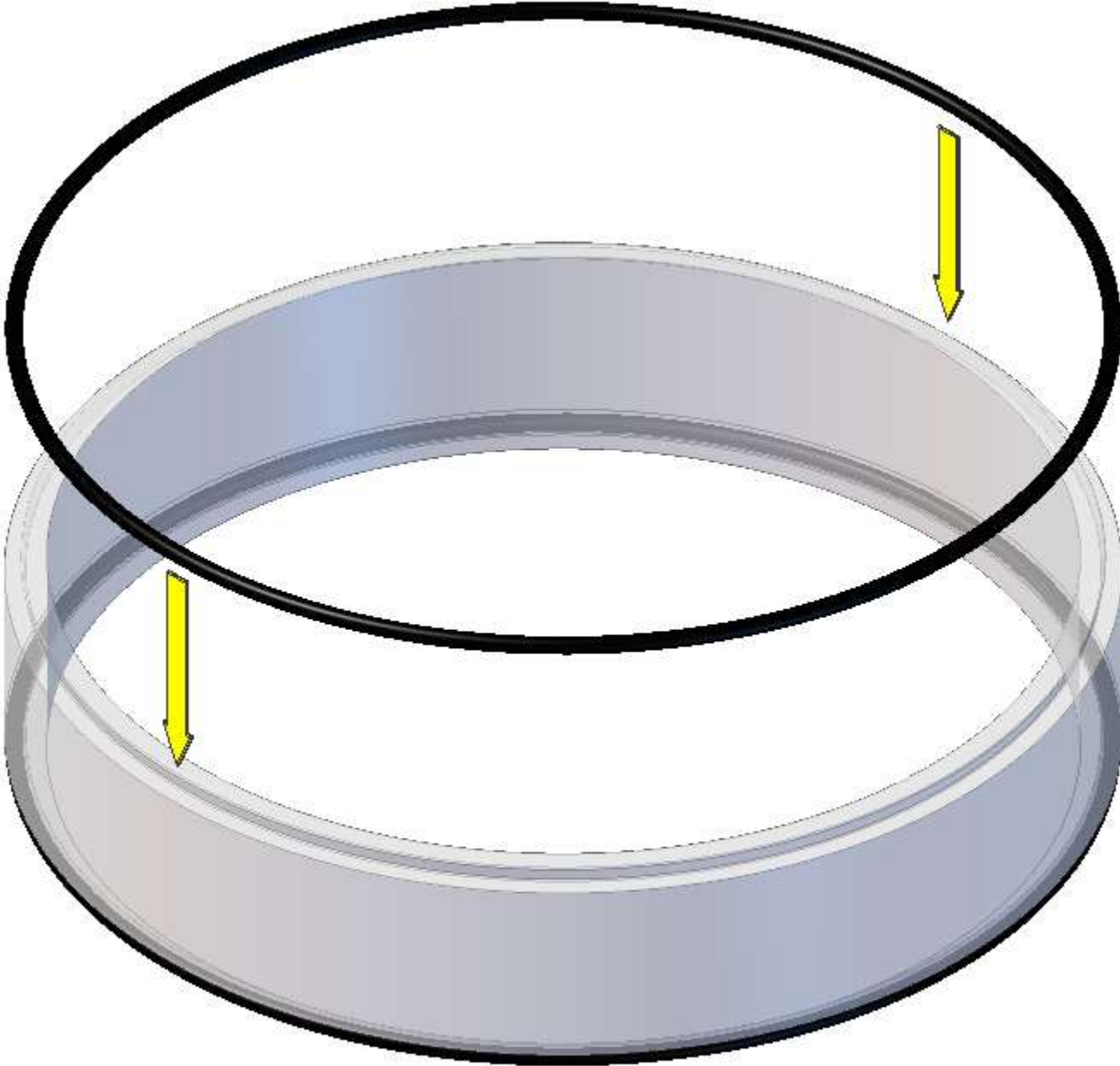

Carefully lower the chamber wall and fitted O rings onto the upturned top plate. Make sure the O rings stay seated in their rebates, and that you do not dislodge any of the chamber pillars.

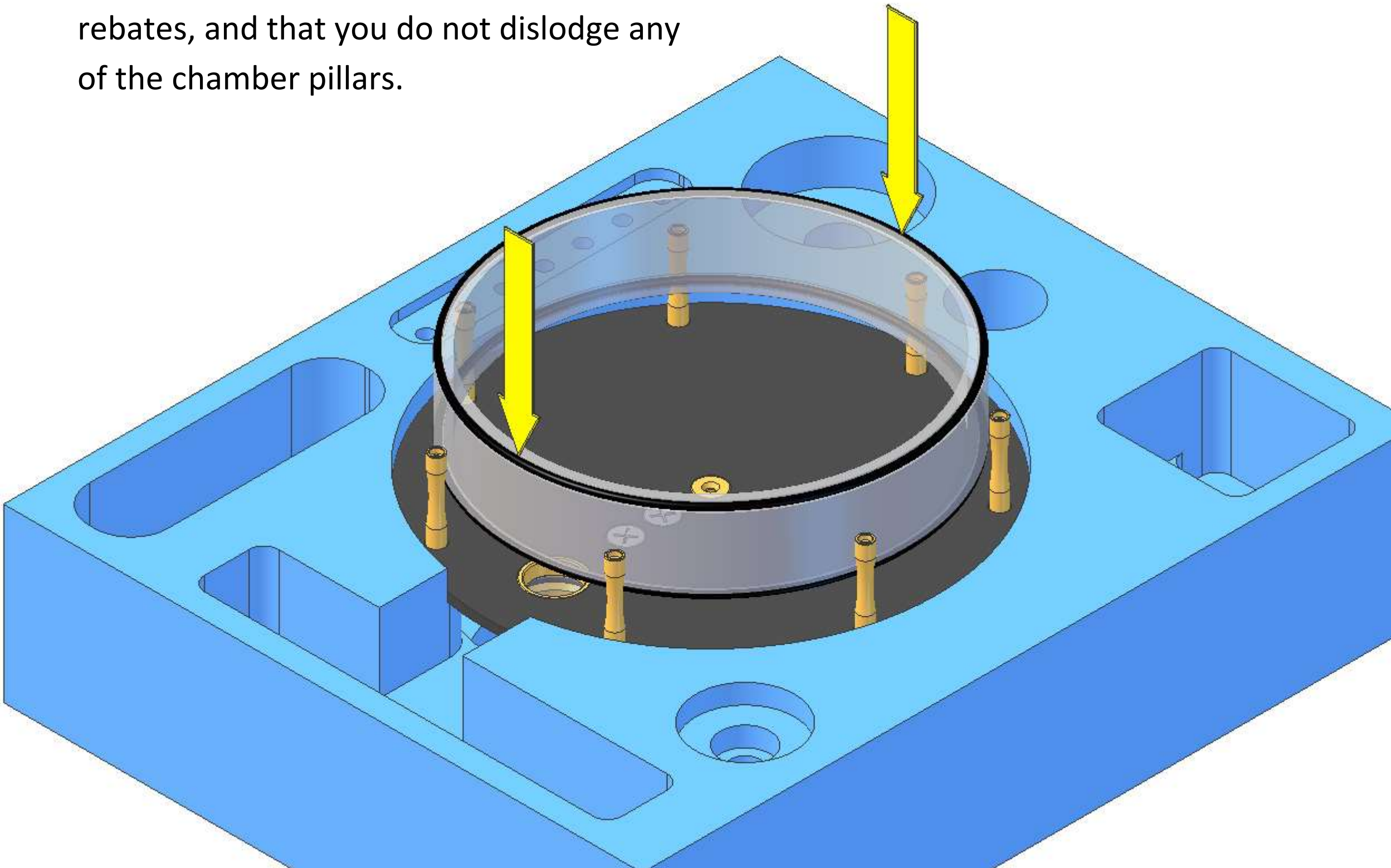

The top face of the displacer has been marked with a coloured dot near the centre.

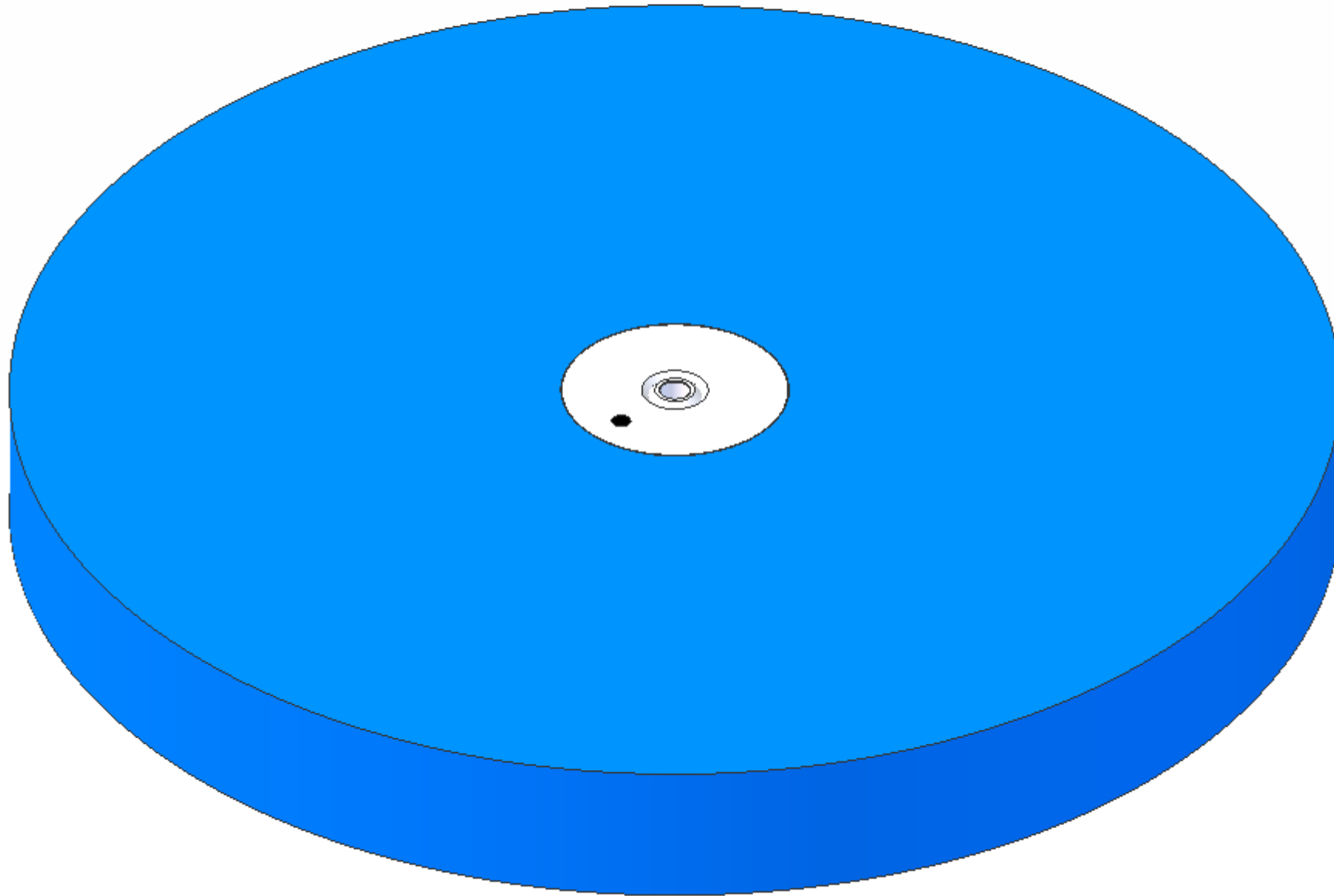

One end of the gland stem is plain and the other has a small through it. The hole-end should point upwards in the next assembly stage.

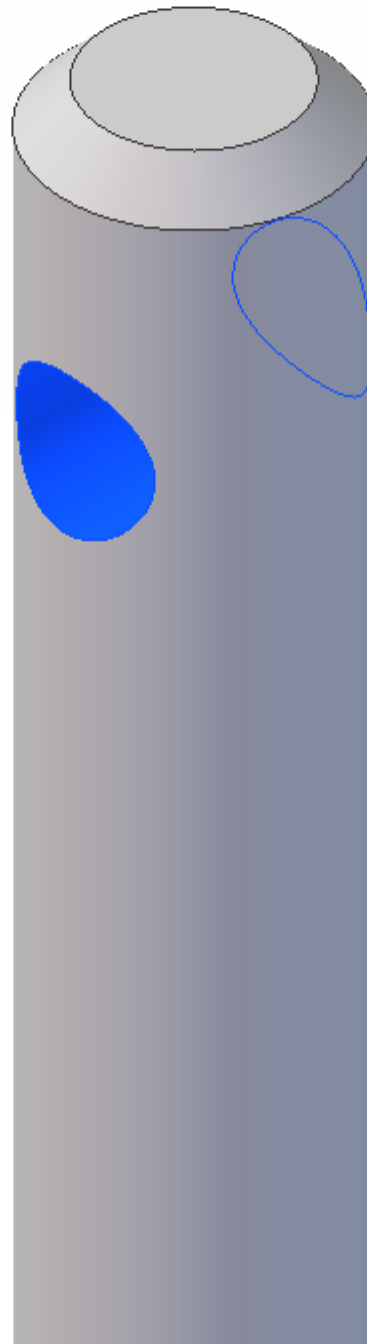

Insert the gland stem hole-end upwards into the top face of the displacer; it will be a reasonably tight fit. You only need to push the stem in a quarter of the way for now; final positioning will be completed at a later stage.

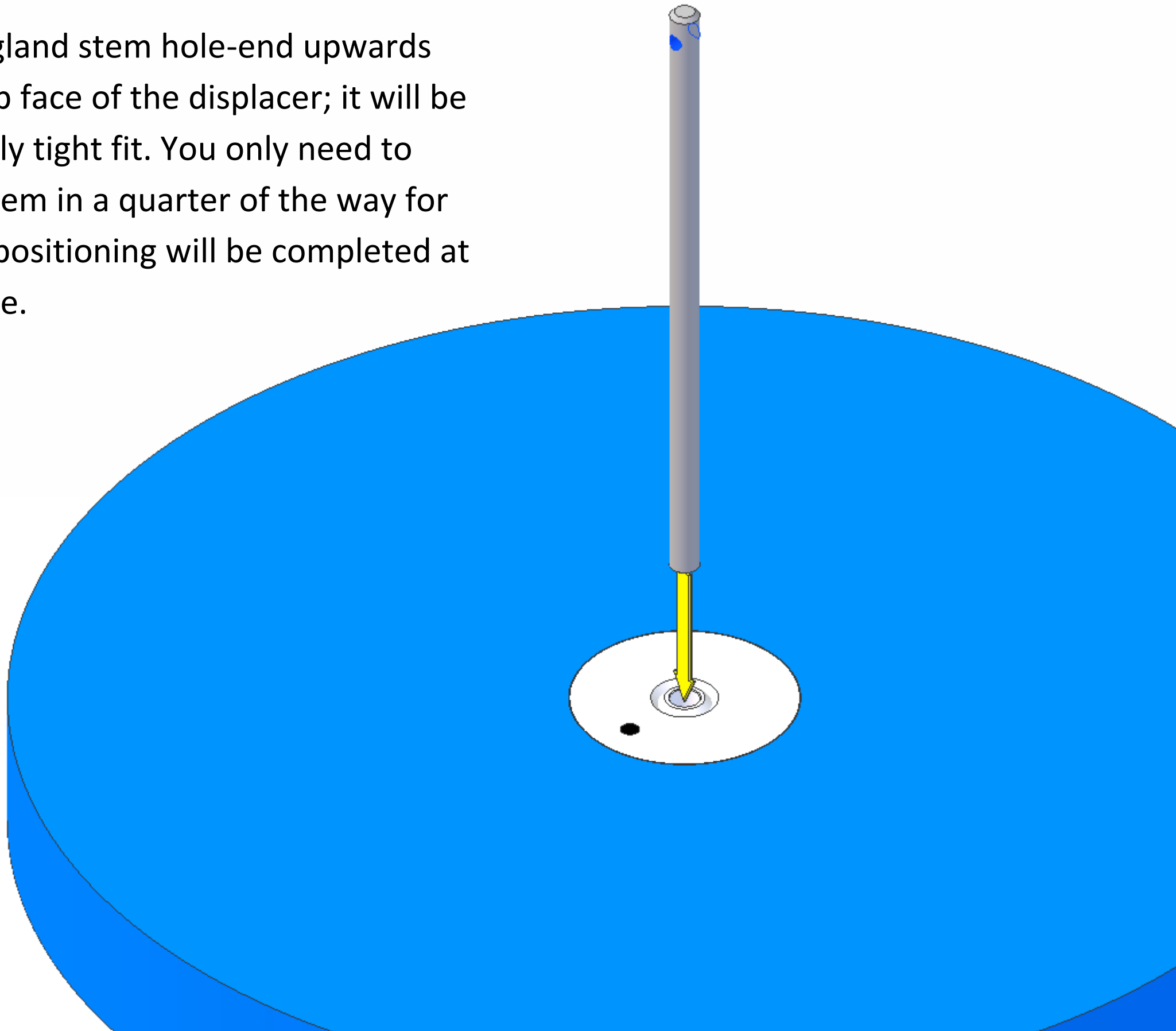

Lower the displacer and stem into the gland.
It should slide freely.

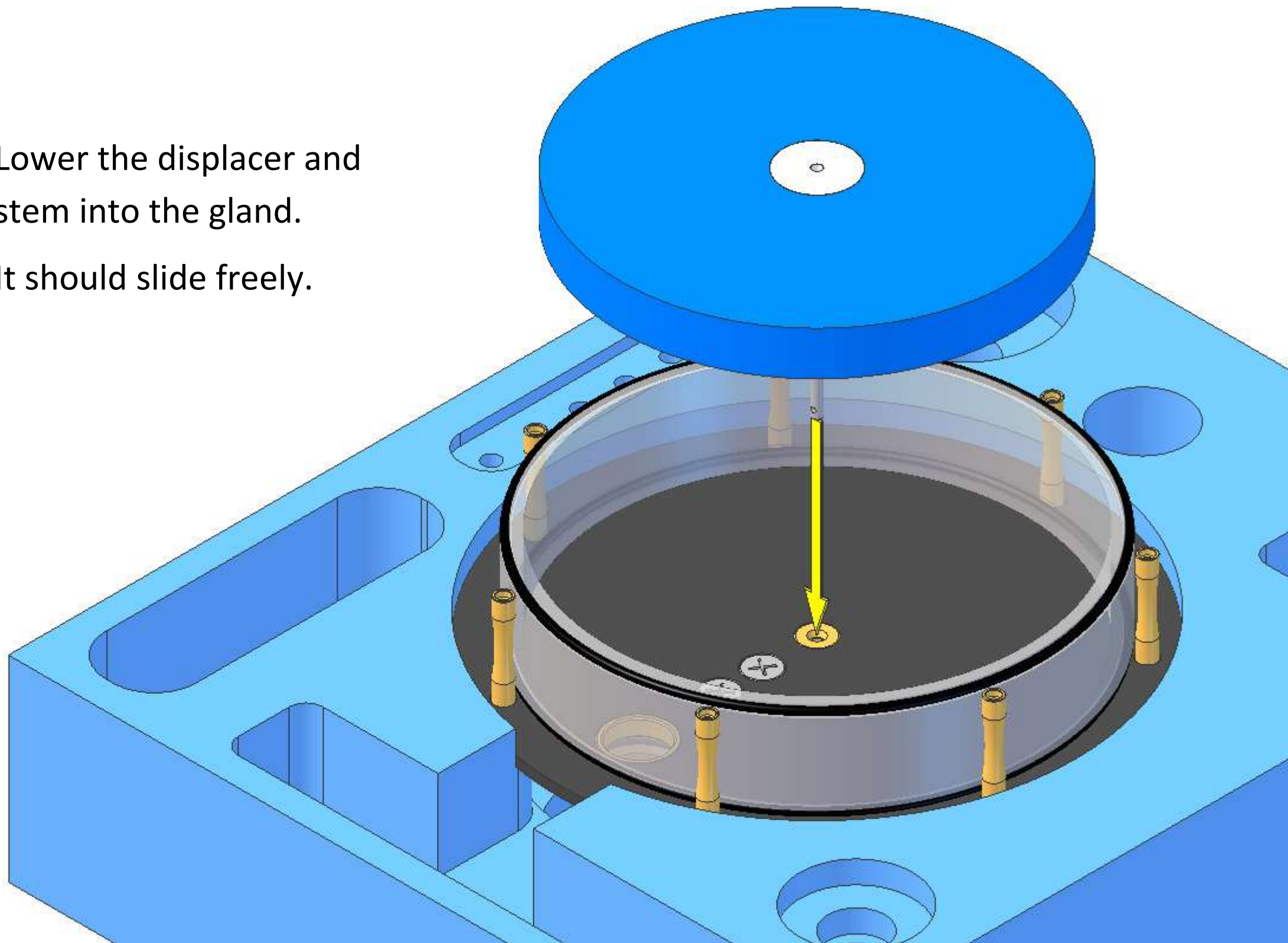

If you have solar (acrylic) or polished (stainless steel) plates you will need to remove the protective film from the bottom plate now. Once you have removed the film try to handle the plate by its edges, this will minimise fingerprints. Solar (acrylic) plates have protective film on both sides, polished (stainless steel) plates have protective film on one side only.

Black and blue (aluminium) plates do not have protective film.

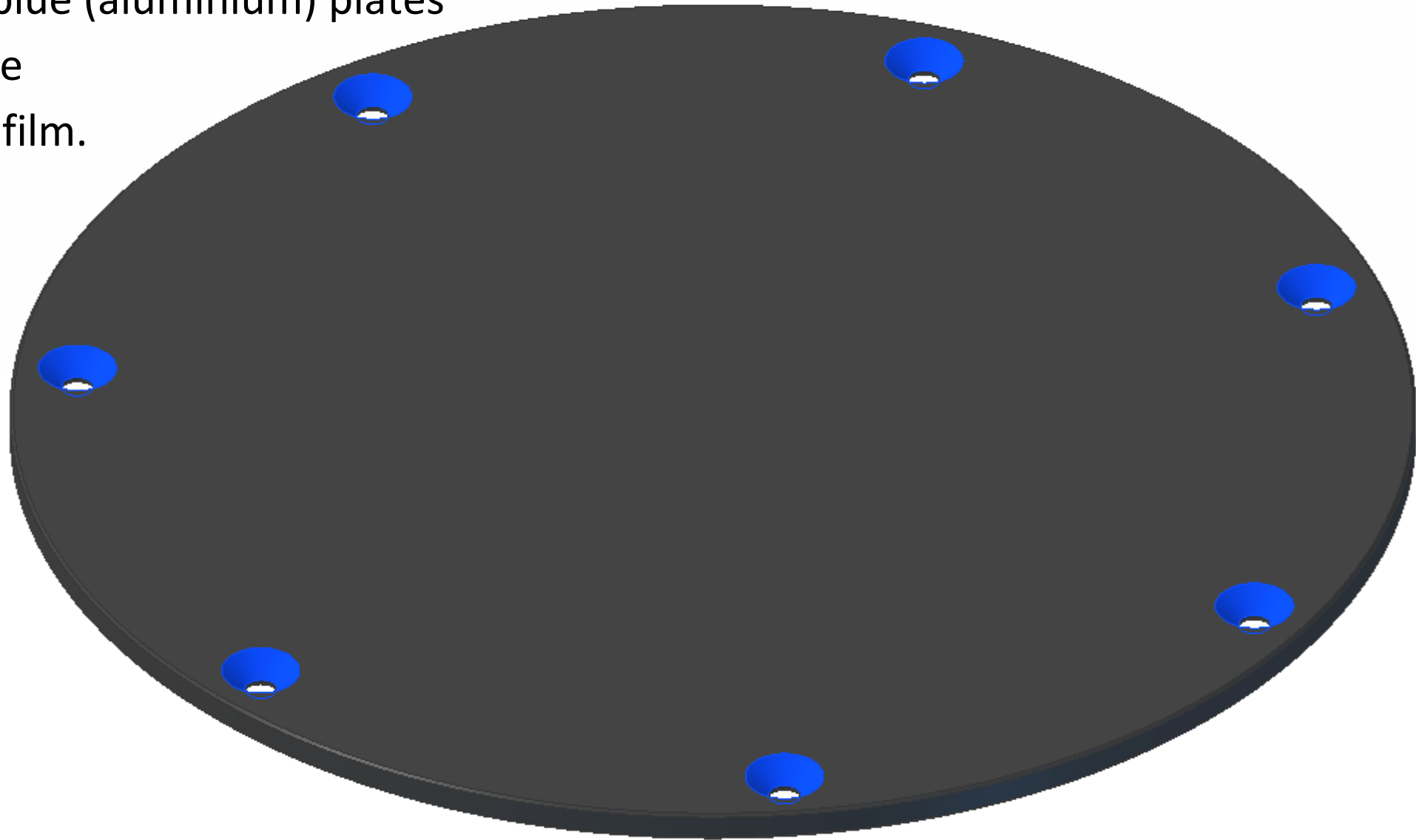

Locate the underside of the bottom plate. The underside is the side with the countersinks on the seven holes as shown in the diagram.

With the underside facing upwards, lower the bottom plate onto the engine. Align the holes in the base plate with the chamber pillars and start inserting seven M2x6mm countersunk screws. Screw each screw nearly all the way in.

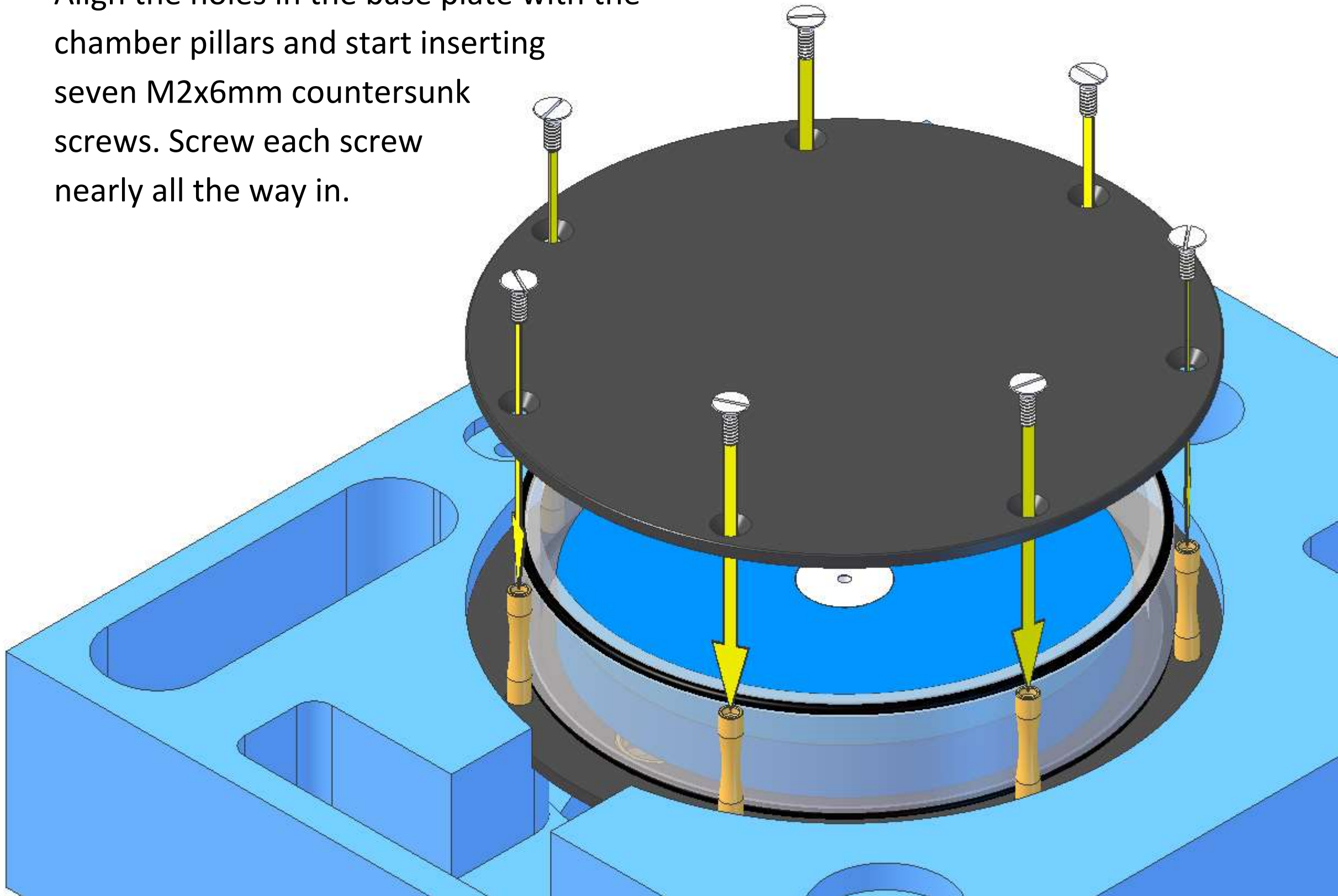

When all the screws are in start to tighten them, you might need to pinch each pillar with thumb and finger to stop it spinning while you tighten the screws.

Work around the screws in the order 1, 3, 5, 7, 2, 4, and 6. Tighten the screws sufficient to hold the plate in place without any sideways movement, any tighter is unnecessary and could damage the screws.

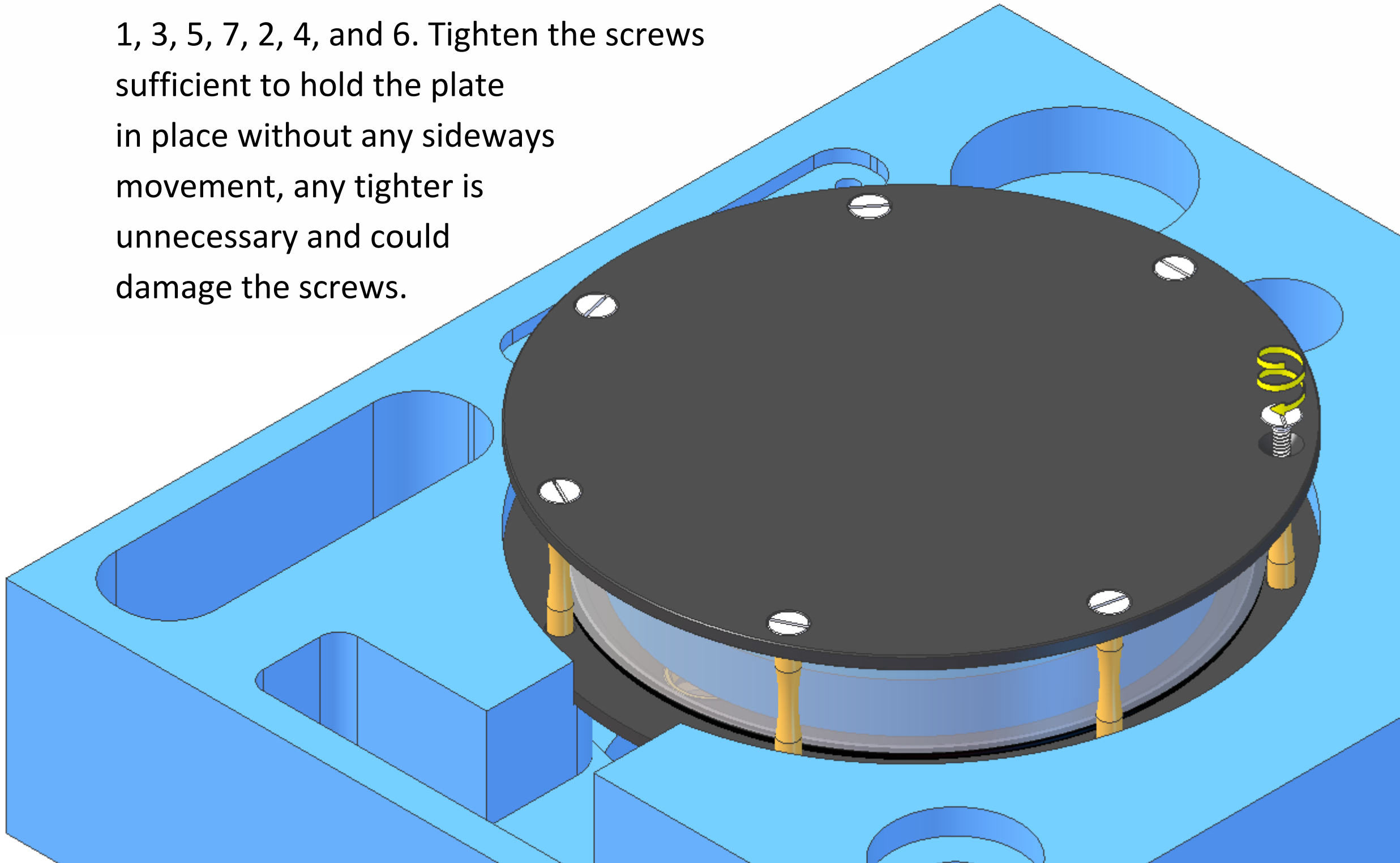

The chamber pillars are deliberately short and will not touch the bottom plate. This is so that they cannot conduct heat directly between the two plates and retard engine performance.

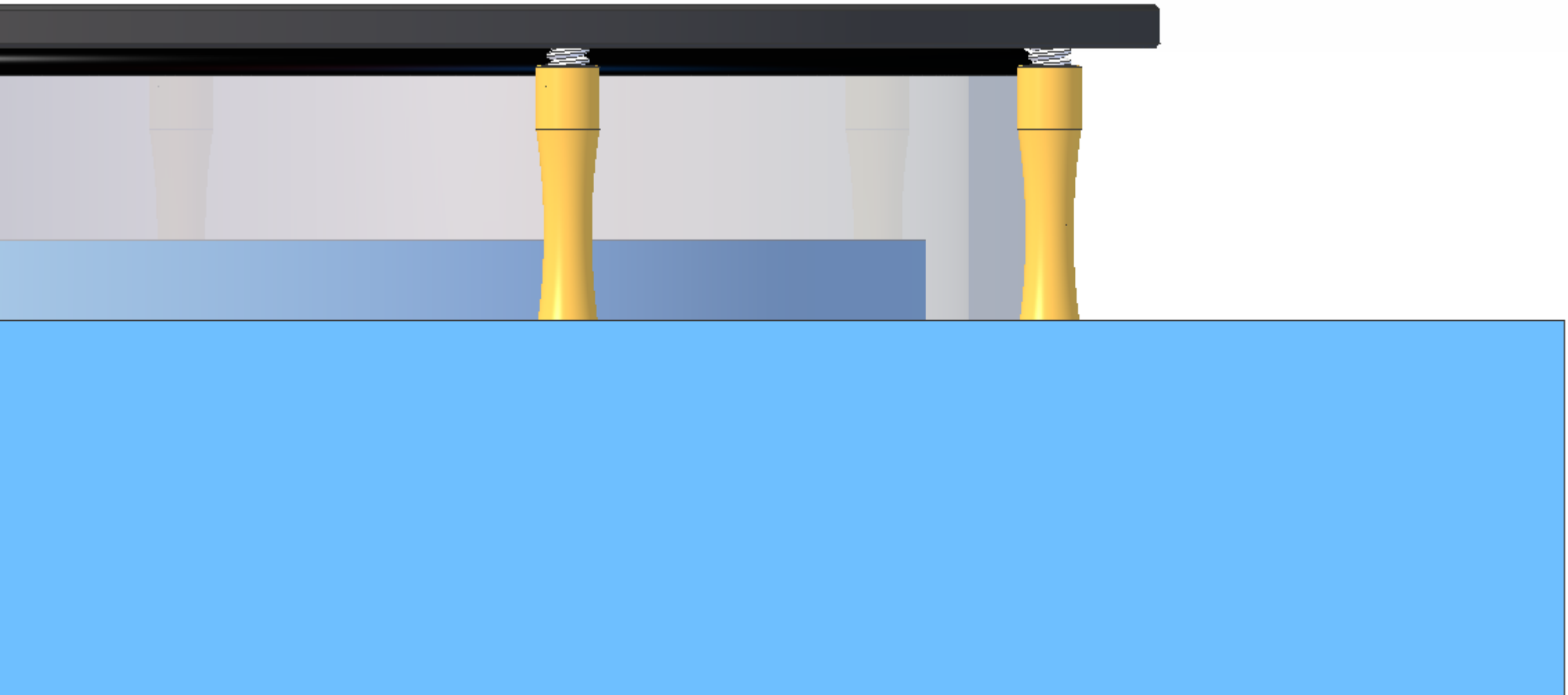

Remove the engine from the packing tray.

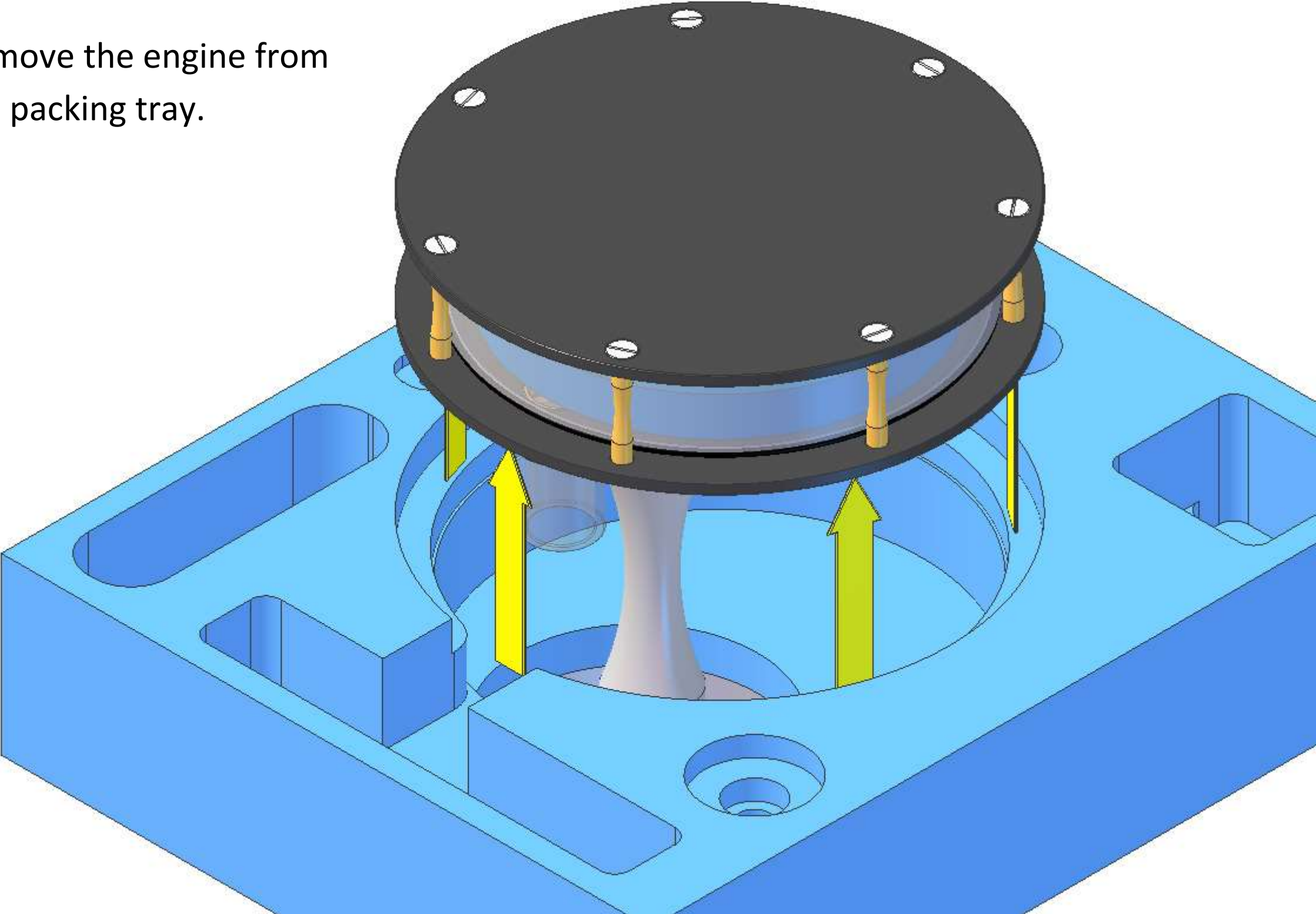

Fit the hub/axle into the flywheel. Screw in three M2x4mm countersunk screws a couple of turns each.

The three holes in the flywheel and hub are spaced so that there is only one way that they will all line up together. This ensures the flywheel counterweight is in the correct position. Note, the three holes in the flywheel are countersunk on one side; this side should be positioned as shown in the diagram.

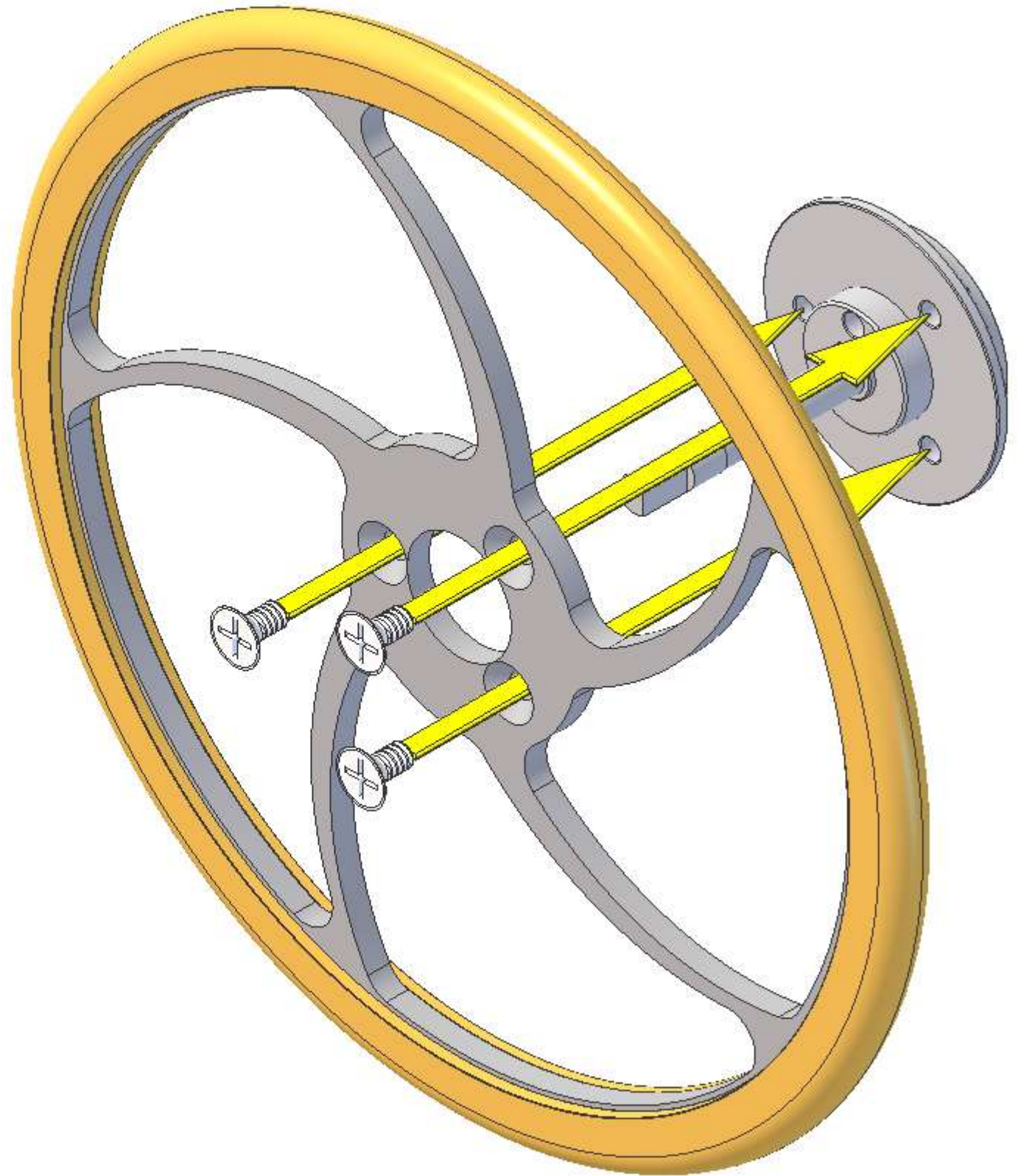

Screw the three screws in until they all lightly touch the flywheel, then fully tighten.

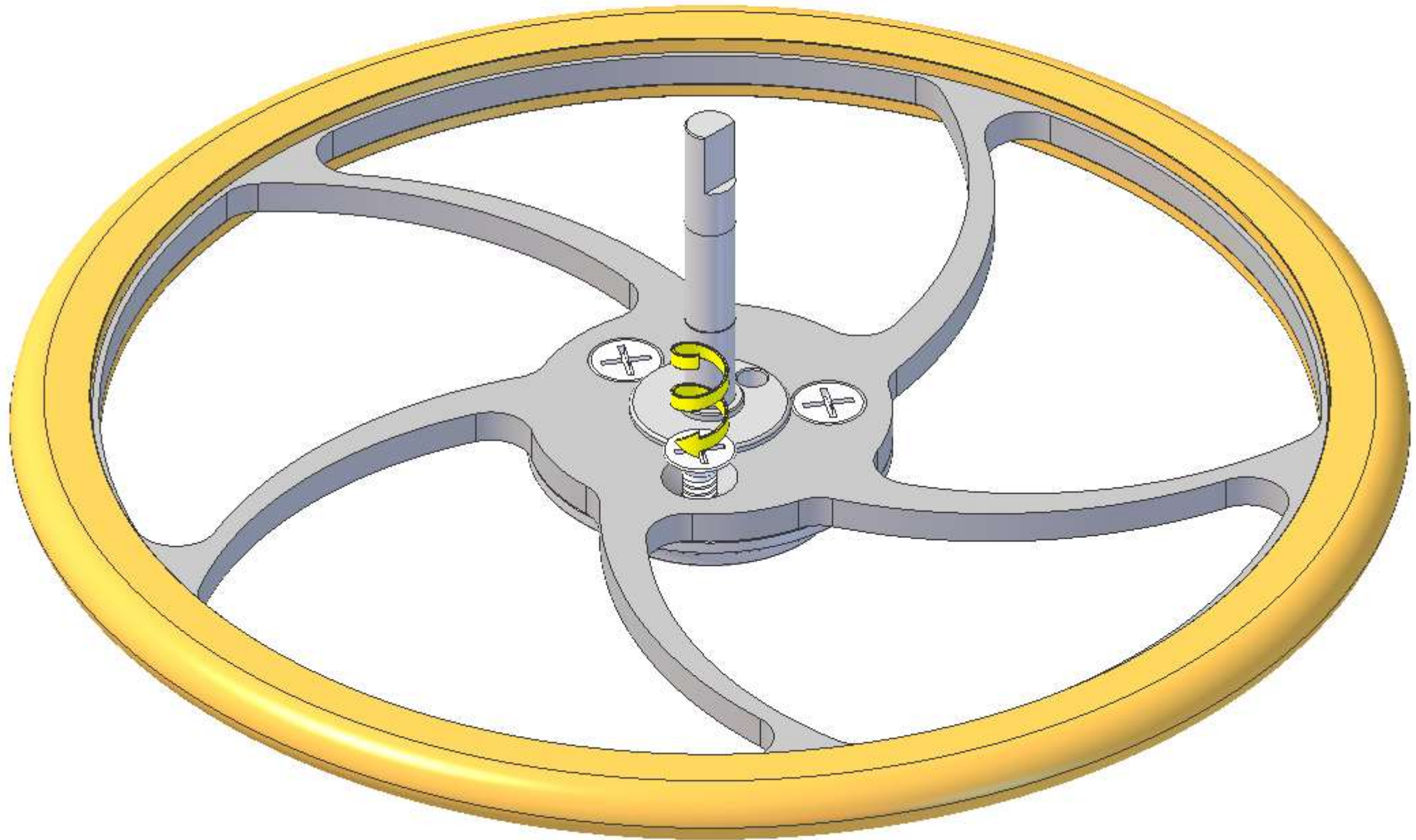

Fit two ball-race bearings into the recesses in the top of the main pillar.

The bearings have a dust shield on one side and are open on the other.

The shielded sides should face outwards after fitting.

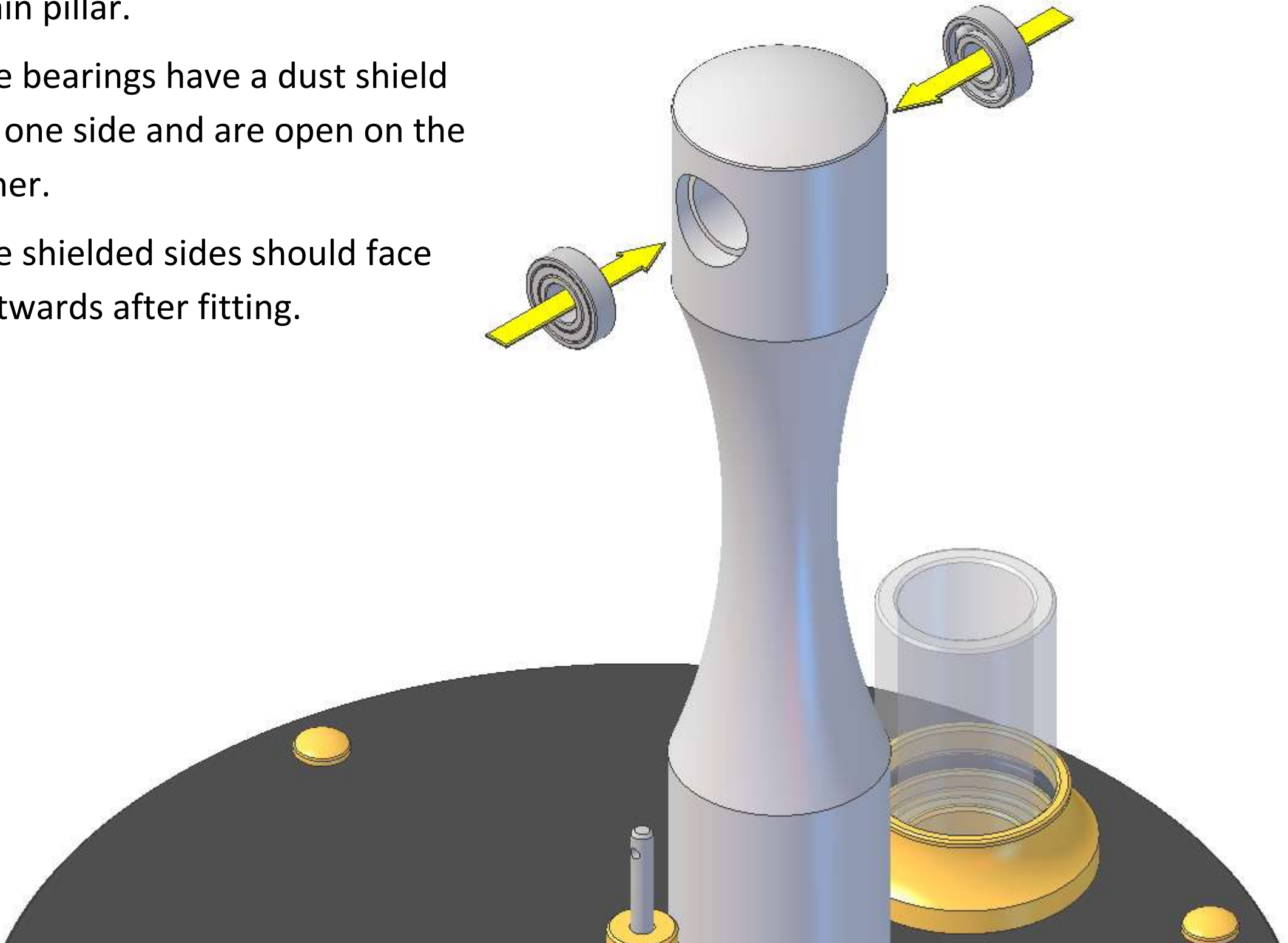

Slide the axle through the bearings. The axle should be a good fit but not tight in the bearings.

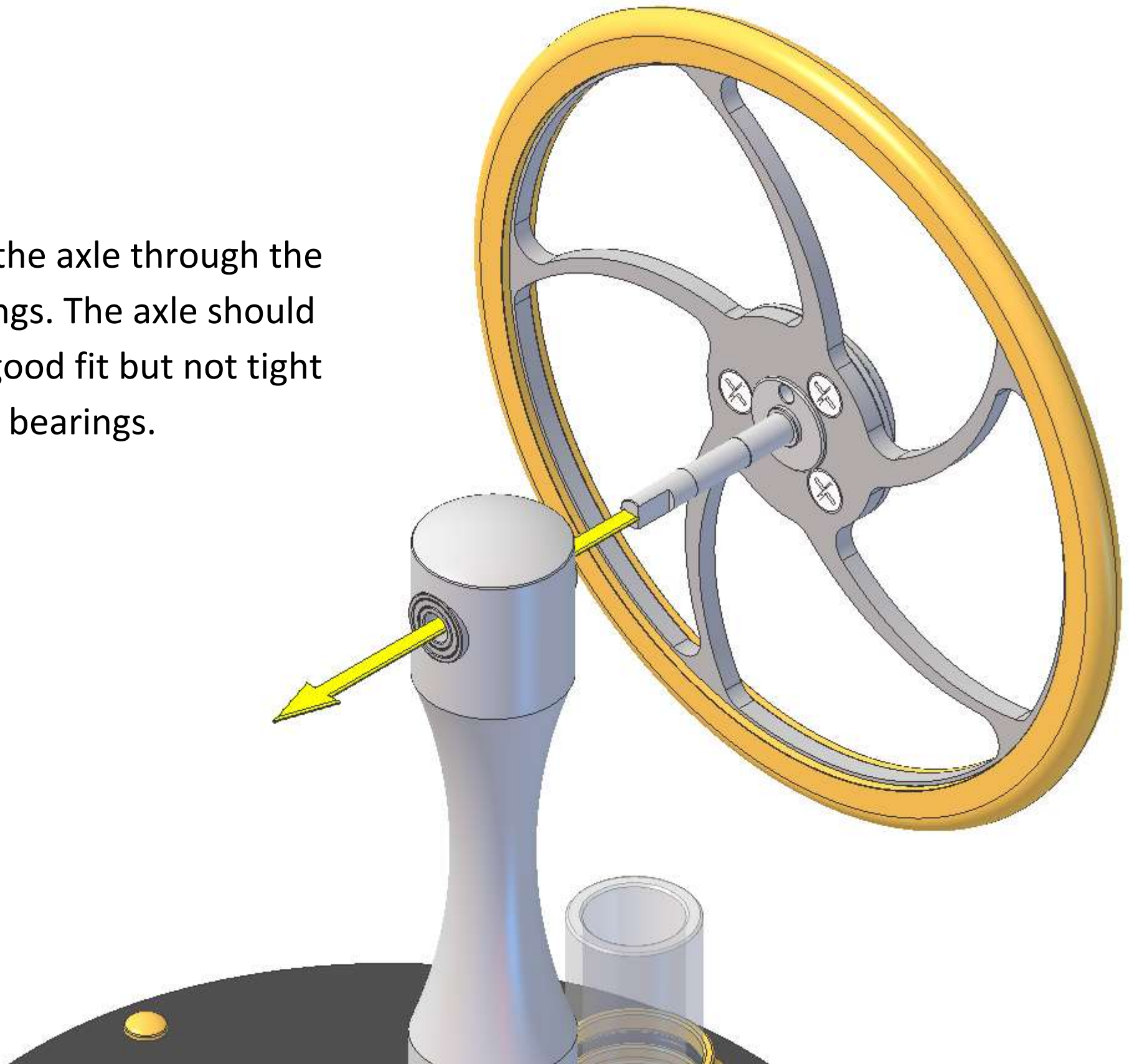

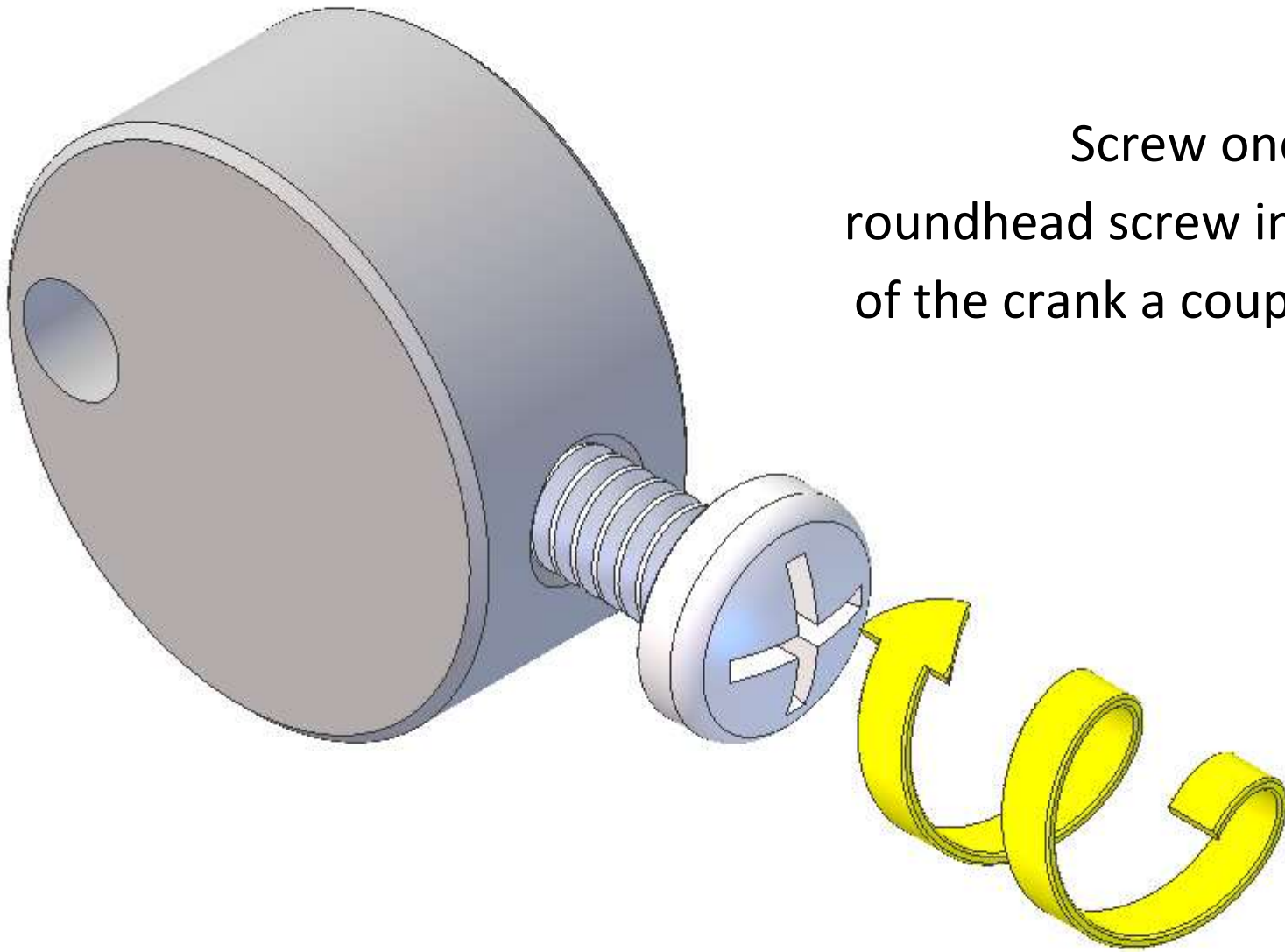

Screw one M2x4mm
roundhead screw into the side
of the crank a couple of turns.

Slide the crank onto the end of the axle. The crank should be a good fit but not tight on the axle.

Note: the screw in the side of the crank must screw onto the small flat on the end of the axle.

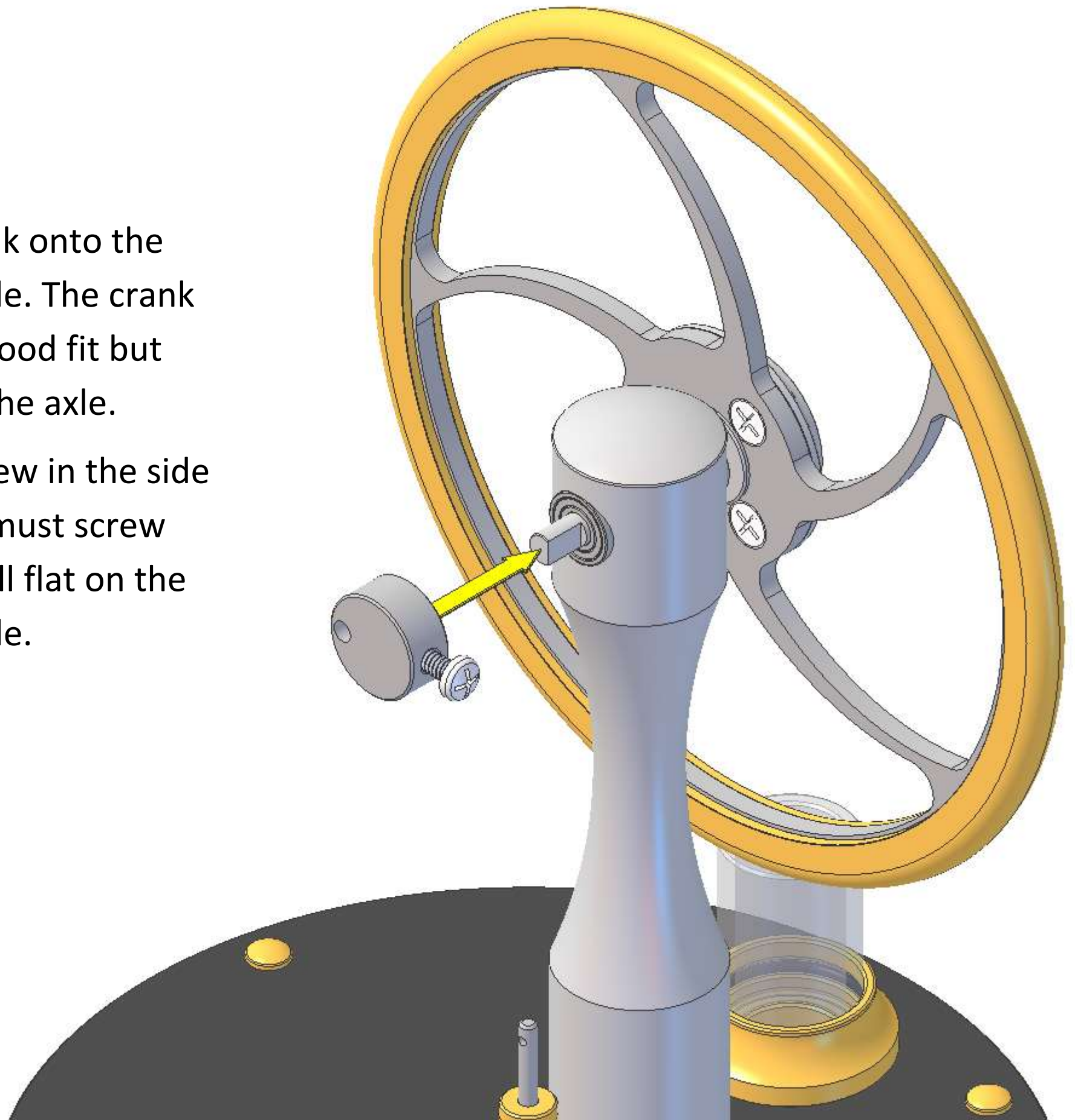

Make sure the crank screw is square on the axle flat, then fully tighten.

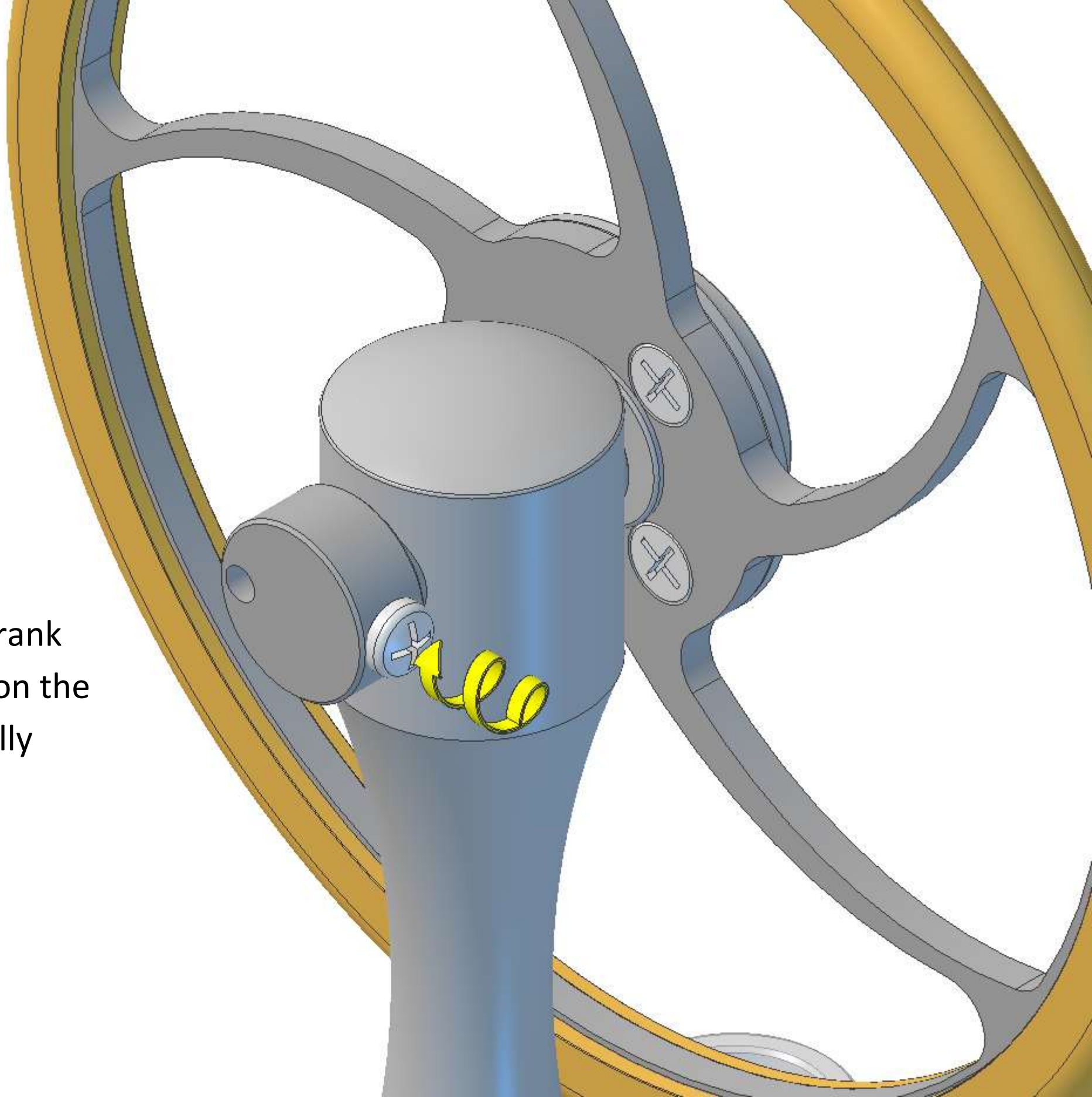

Gently push the flywheel back and forward, there should be a small amount of movement here. If there is not, slacken the crank screw, move the crank out a fraction and tighten. Make sure that when tightening the crank screw again it stays located on the small flat section on the axle.

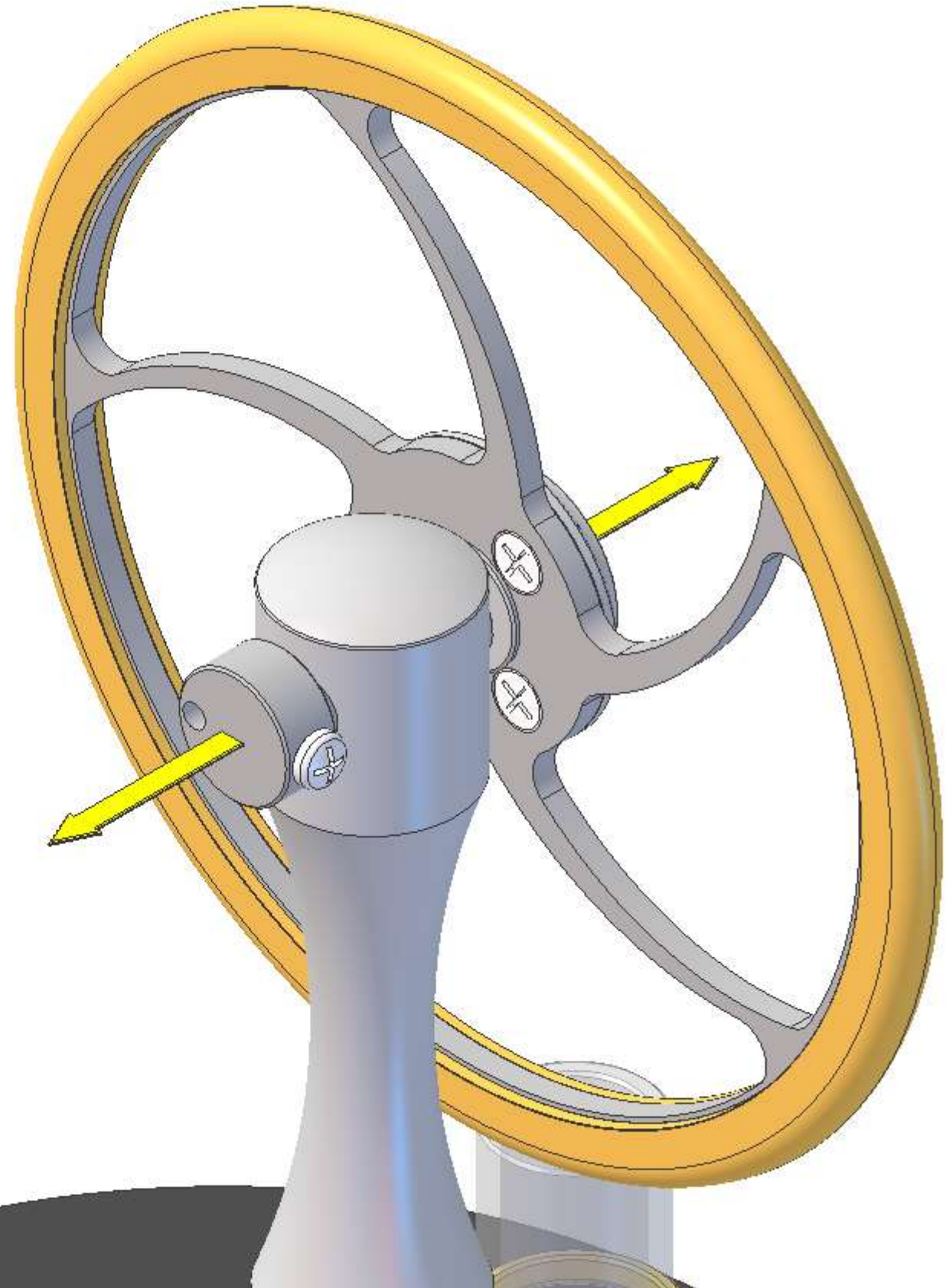

Give the flywheel a sharp spin; it should keep spinning for several minutes.

If it does not then you will need to go back and move the crank out a fraction more.

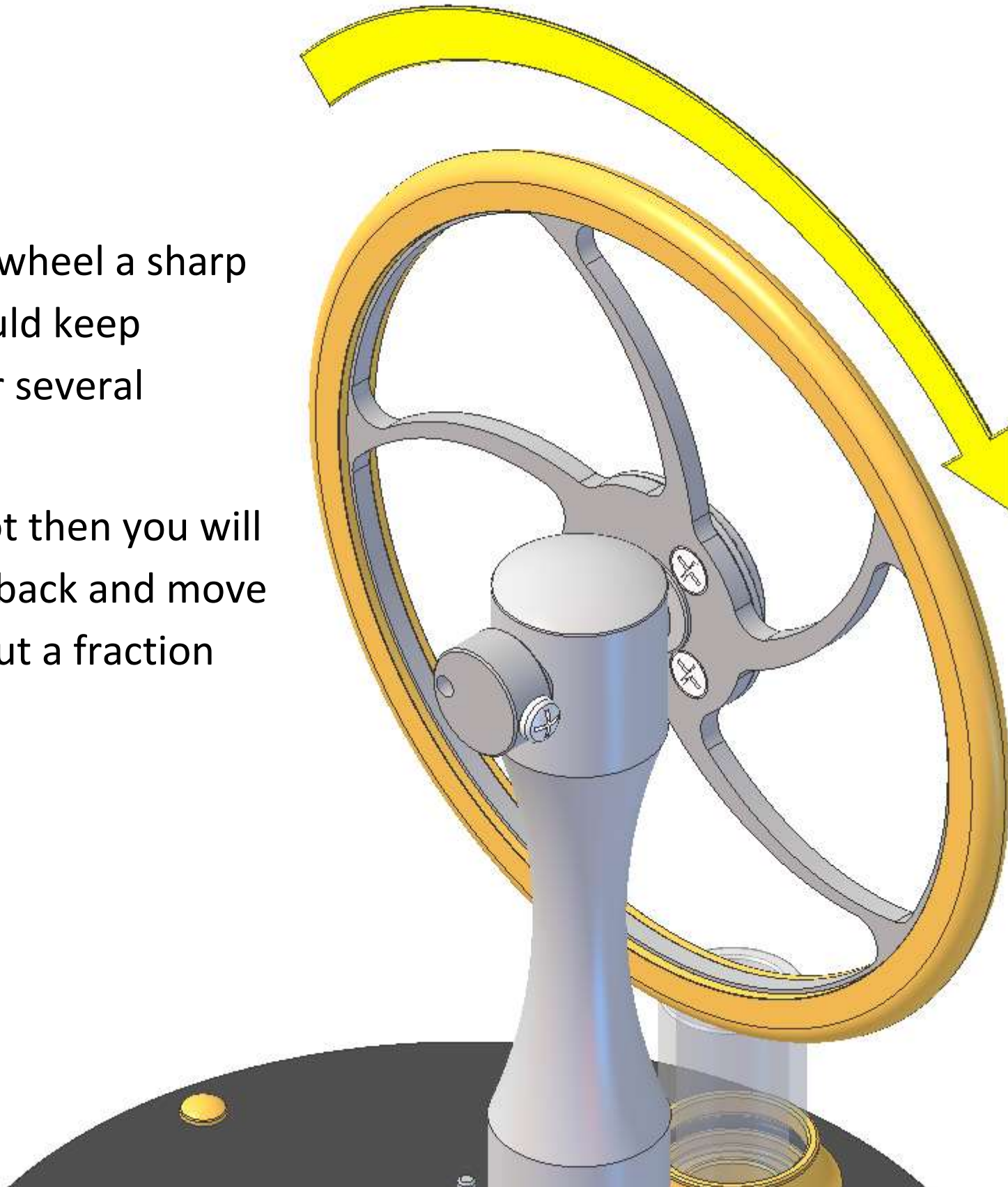

Note: Pre-assembled from late 2016 onwards.

Fit one conrod onto one conrod bush and secure with one M2x6mm roundhead screw. The screw only needs screwing in a couple of turns at this stage.

Note: the hook on the bottom of the conrod should be aligned as shown in the diagram.

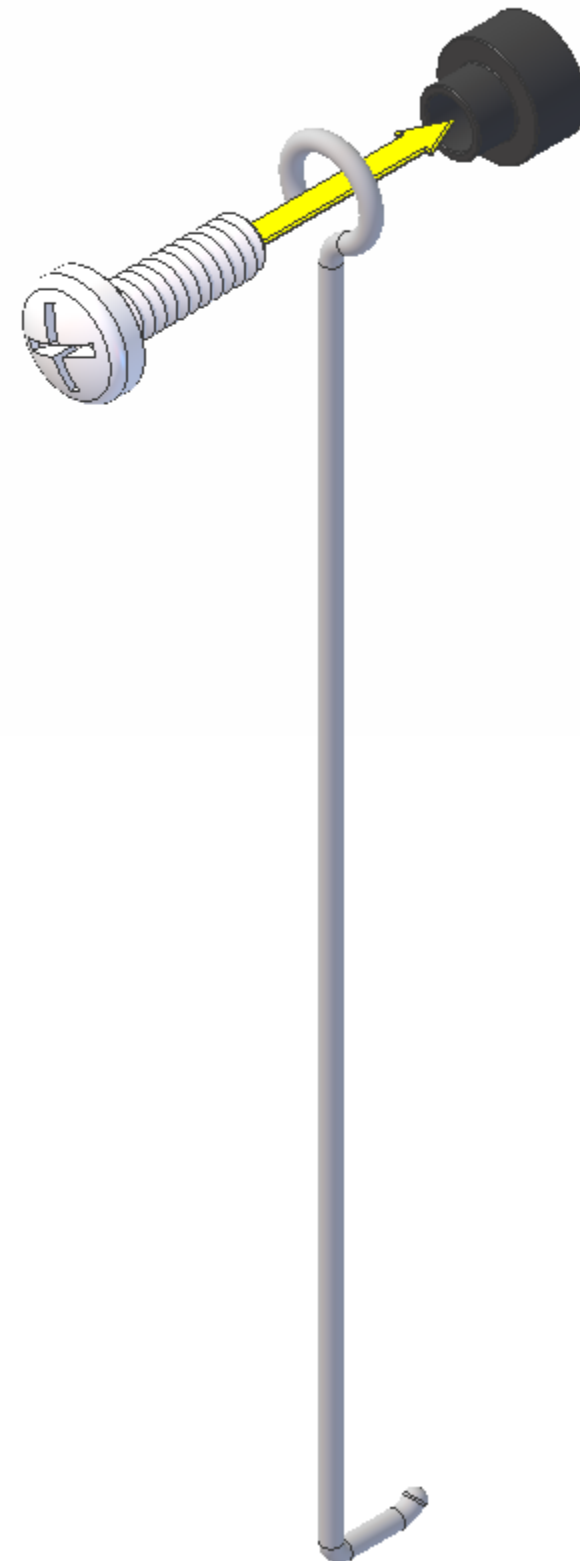

Note: Pre-assembled from late 2016 onwards.

Screw the screw in until it *just* touches the bush. Do not over-tighten or you could cause the bush to expand and pinch the conrod eye, which could prevent your engine from running.

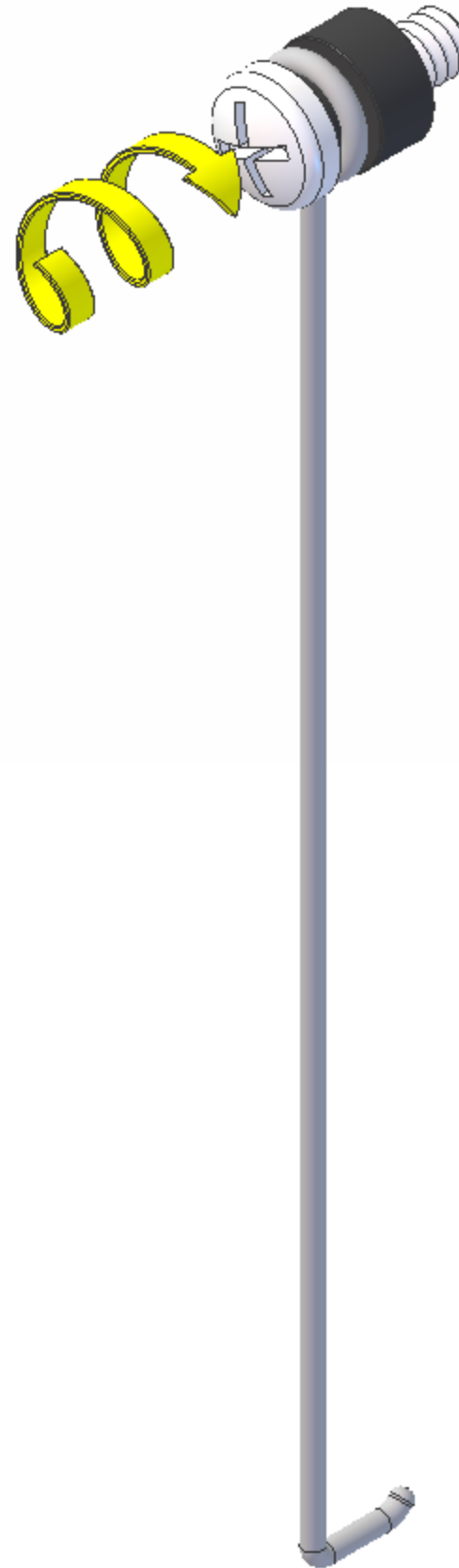

Fit the hook on the
conrod through the
hole in the top of
the gland stem.

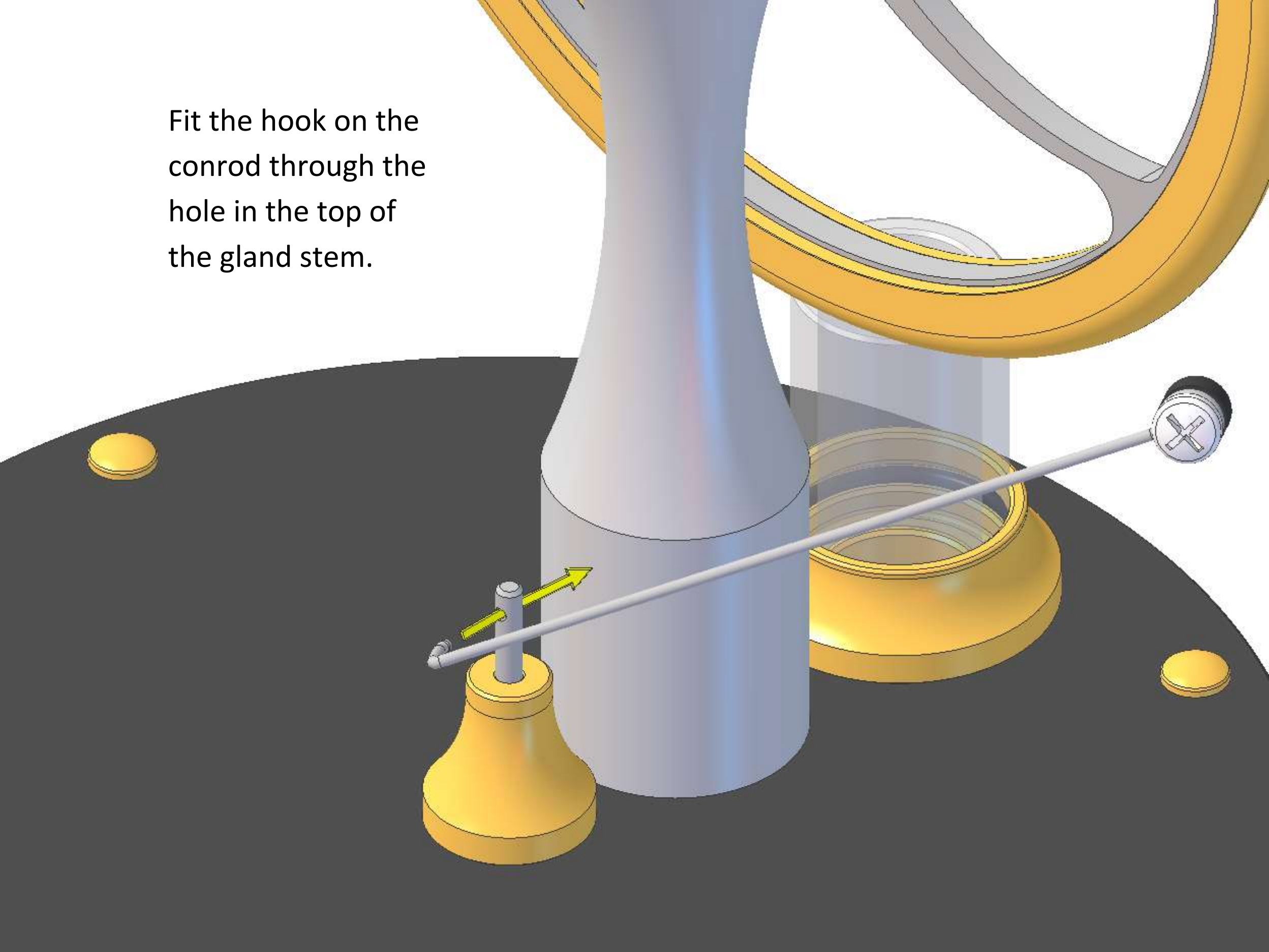

Screw the conrod screw into the hole in the front face of the crank. Tighten only sufficient to lock, over-tightening will cause the conrod bush to expand and pinch the conrod eye, which could prevent your engine from running.

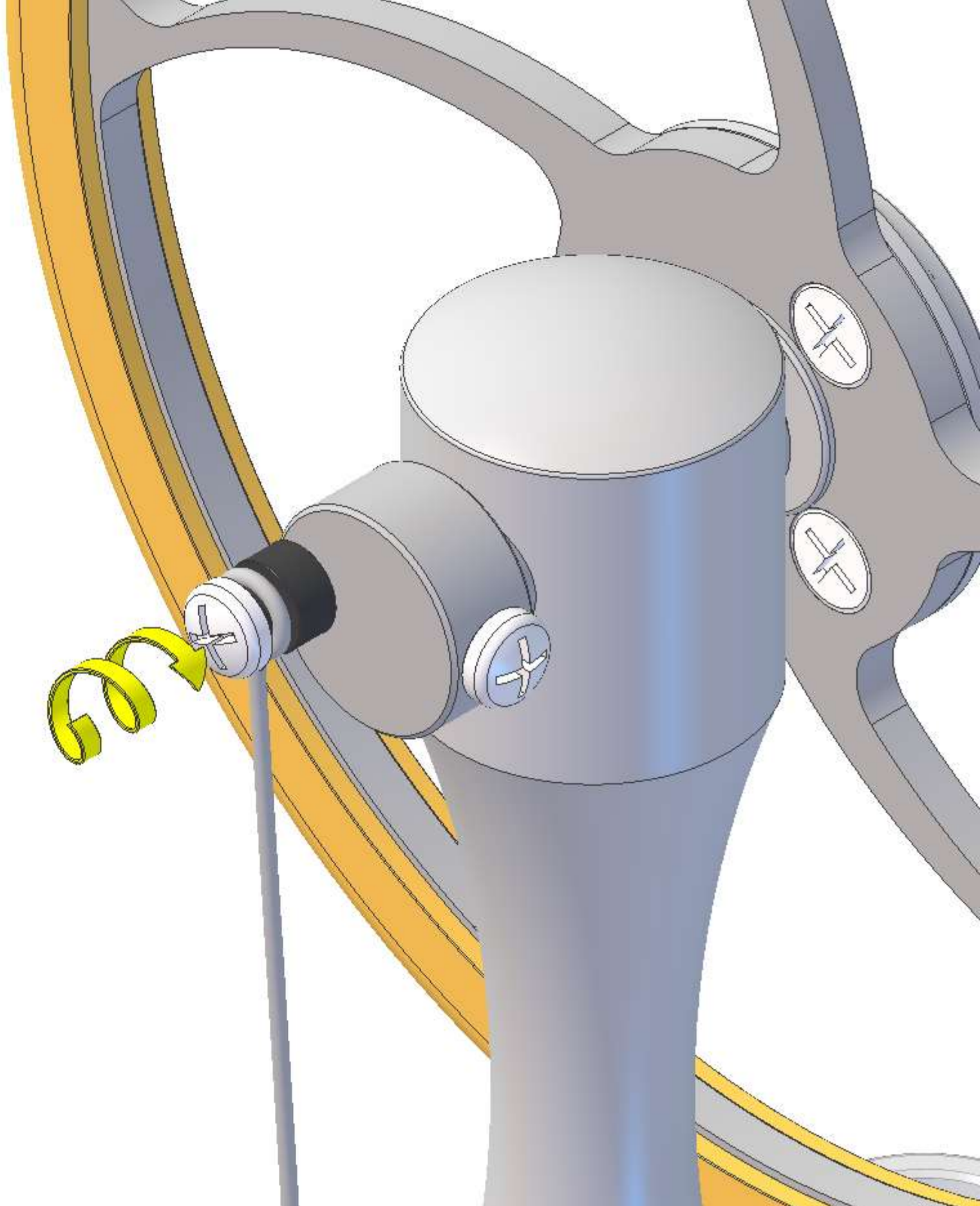

Gently press downwards on the top of the gland stem with the side of a flat screwdriver until the crank and conrod are at their lowest position. This will press the stem into the displacer and set the displacer to its correct position in the chamber. There is a small amount of flex in the conrod, you should be able to take advantage of this and "over-press" the top of the stem so that when you release the pressure on the screwdriver the displacer lifts off the bottom plate slightly.

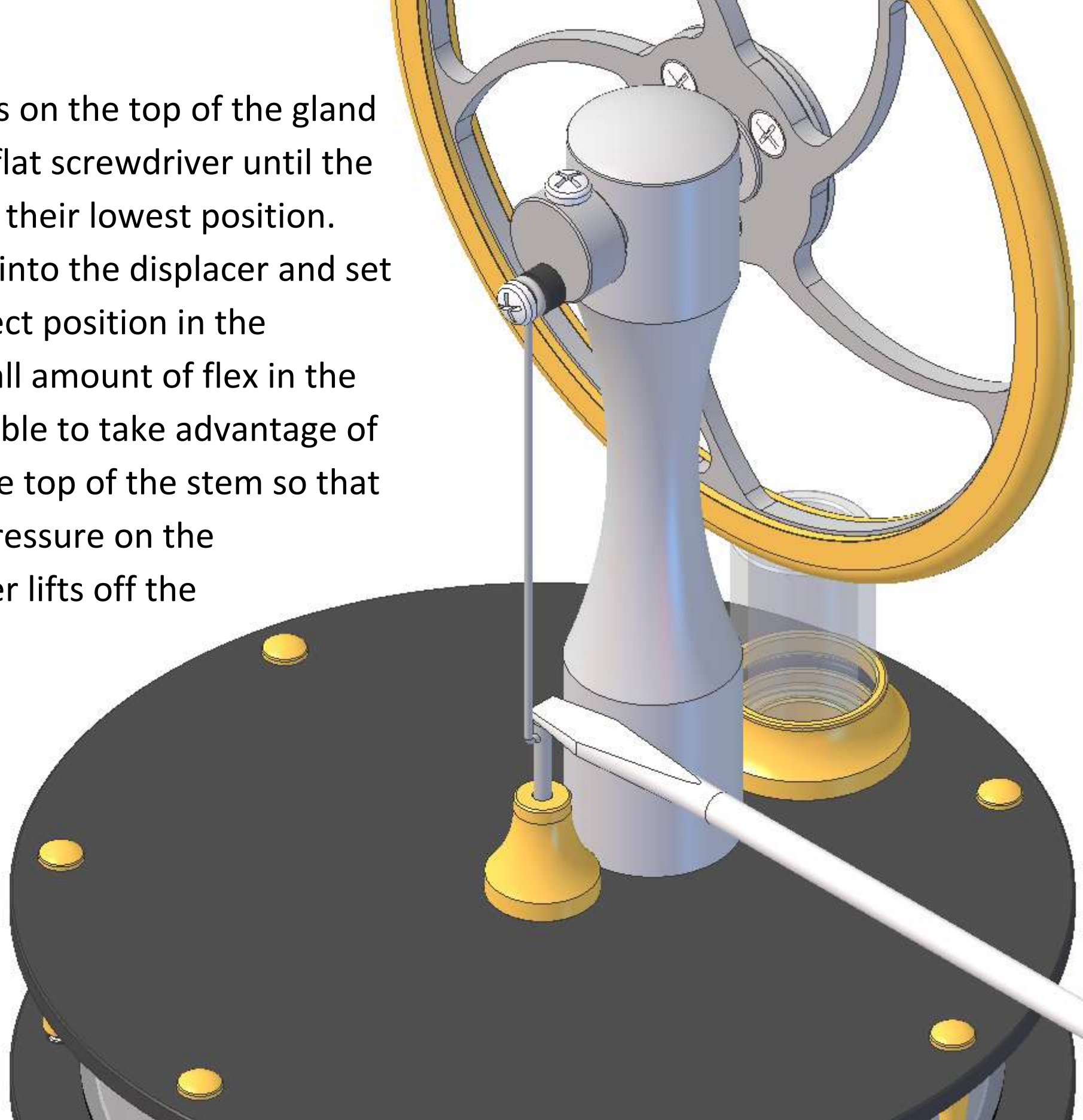

Slowly rotate the flywheel to move the displacer up and down in the chamber. Check that it does not touch the bottom plate. If it does touch you can go back and press the top of the gland stem some more.

Note, the chamber wall and 75mm O rings are shown cut away for clarity.

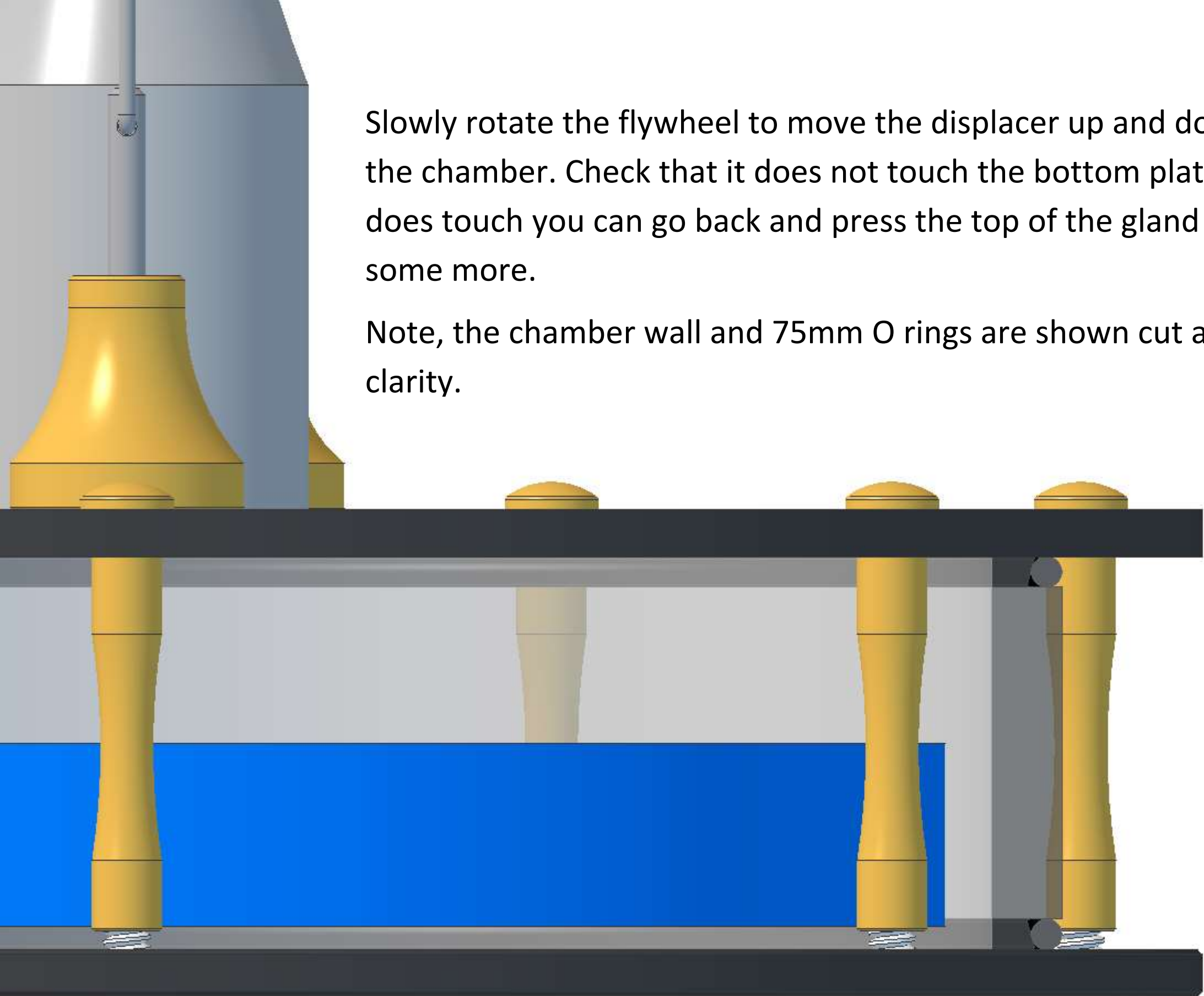

Check that the displacer does not touch the top plate. If it does you will need to unscrew the top of the conrod from the crank, leave it hooked in the gland stem and use it to pull the stem up in the displacer a small amount. Be careful not to bend the hook on the bottom of the conrod when doing this. Ideally the displacer should have an even gap at the top and bottom of its stroke. Re-check and adjust until the displacer does not touch either plate.

Note, the chamber wall and 75mm O rings are shown cut away for clarity.

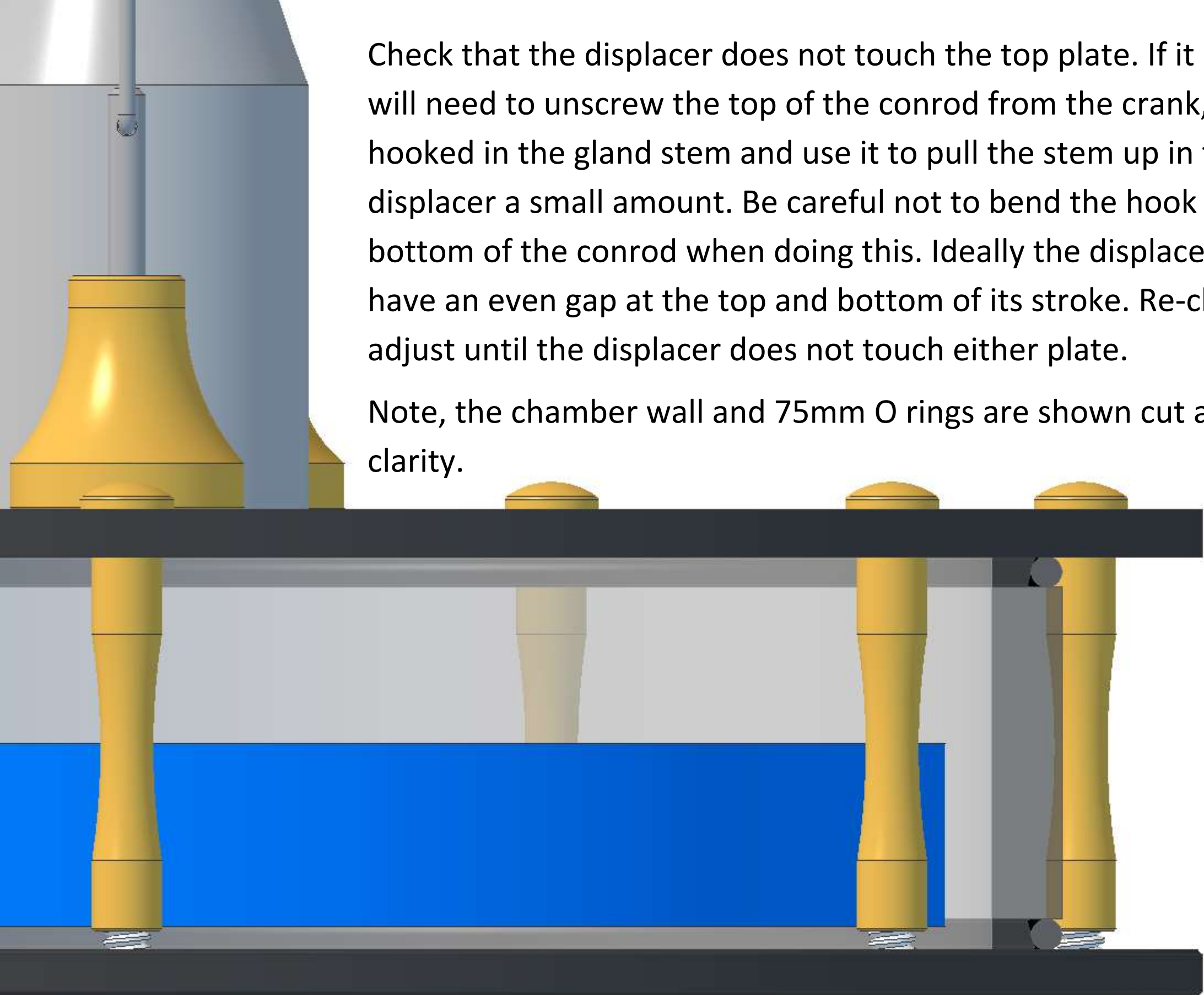

Note: Pre-assembled from late 2016 onwards.

Fit one conrod onto one conrod bush and secure with one M2x6mm roundhead screw. The screw only needs screwing in a couple of turns at this stage.

Note: the hook on the bottom of the conrod should be aligned as shown in the diagram.

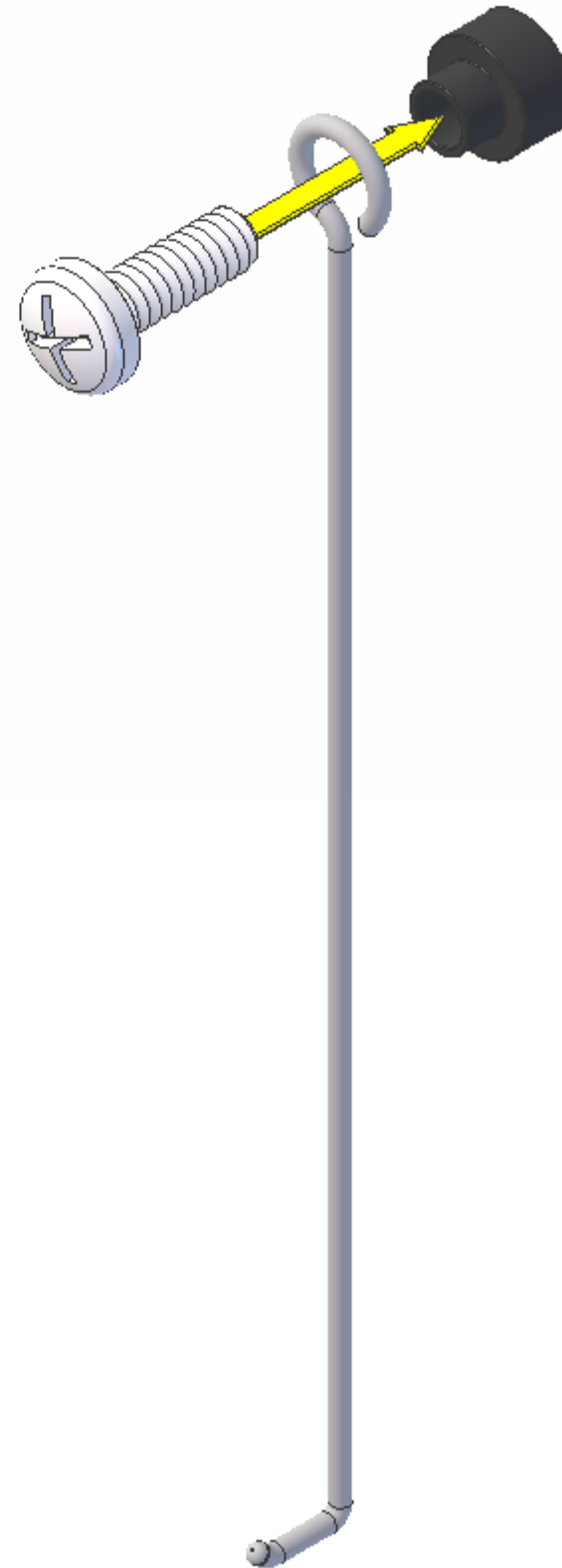

Note: Pre-assembled from late 2016 onwards.

Screw the screw in until it just touches the bush. Do not over-tighten or you could cause the bush to expand and pinch the conrod eye, which could prevent your engine from running.

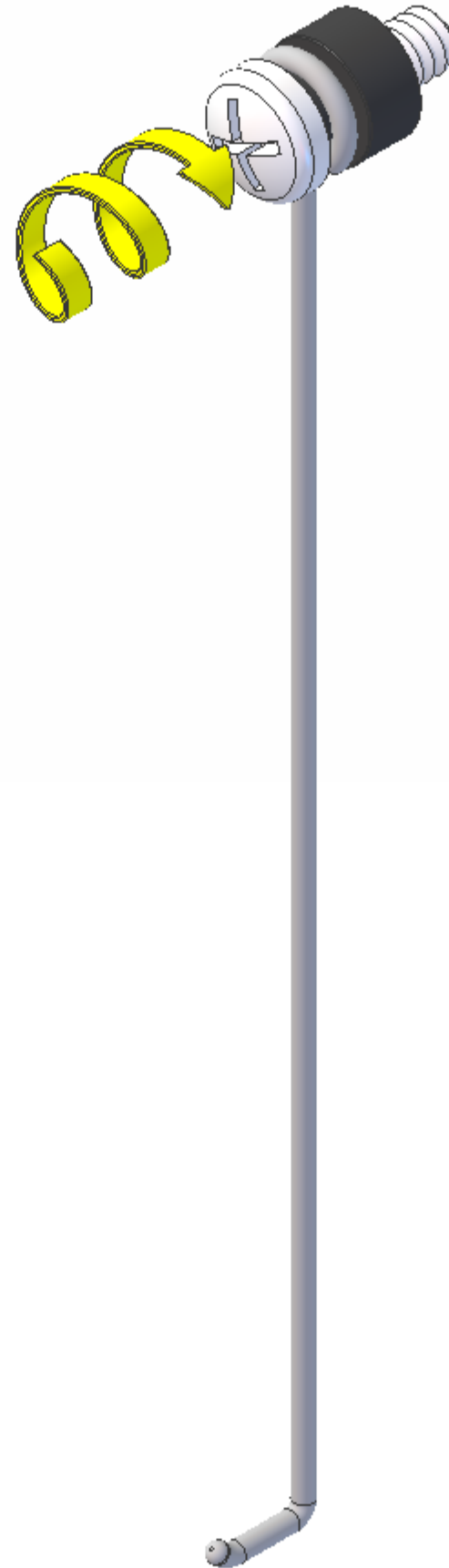

Fit the hook on the
conrod through the hole
in the top of the piston.

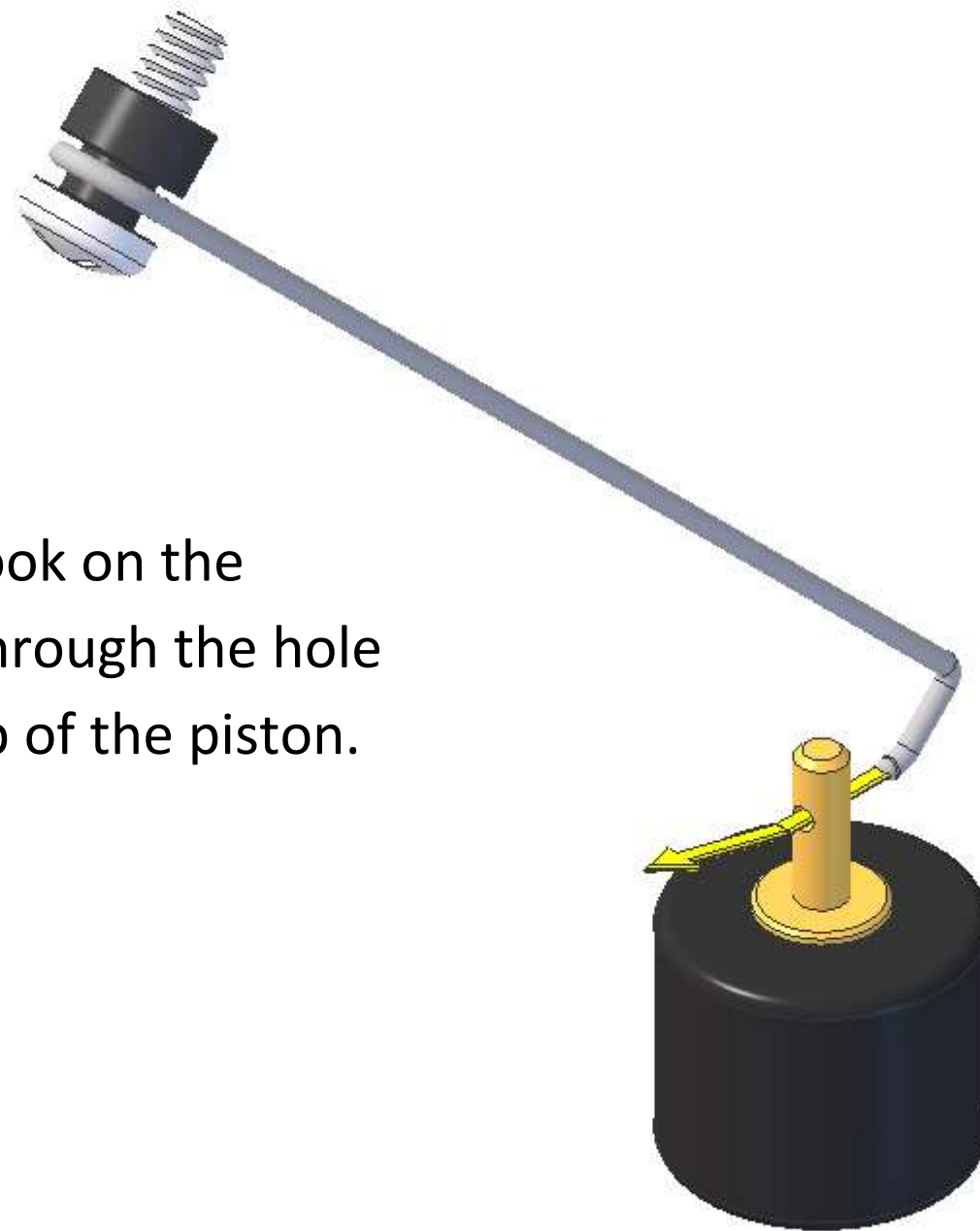

Slide the piston and conrod into the cylinder.
Some air pressure should be felt as you slide it in.

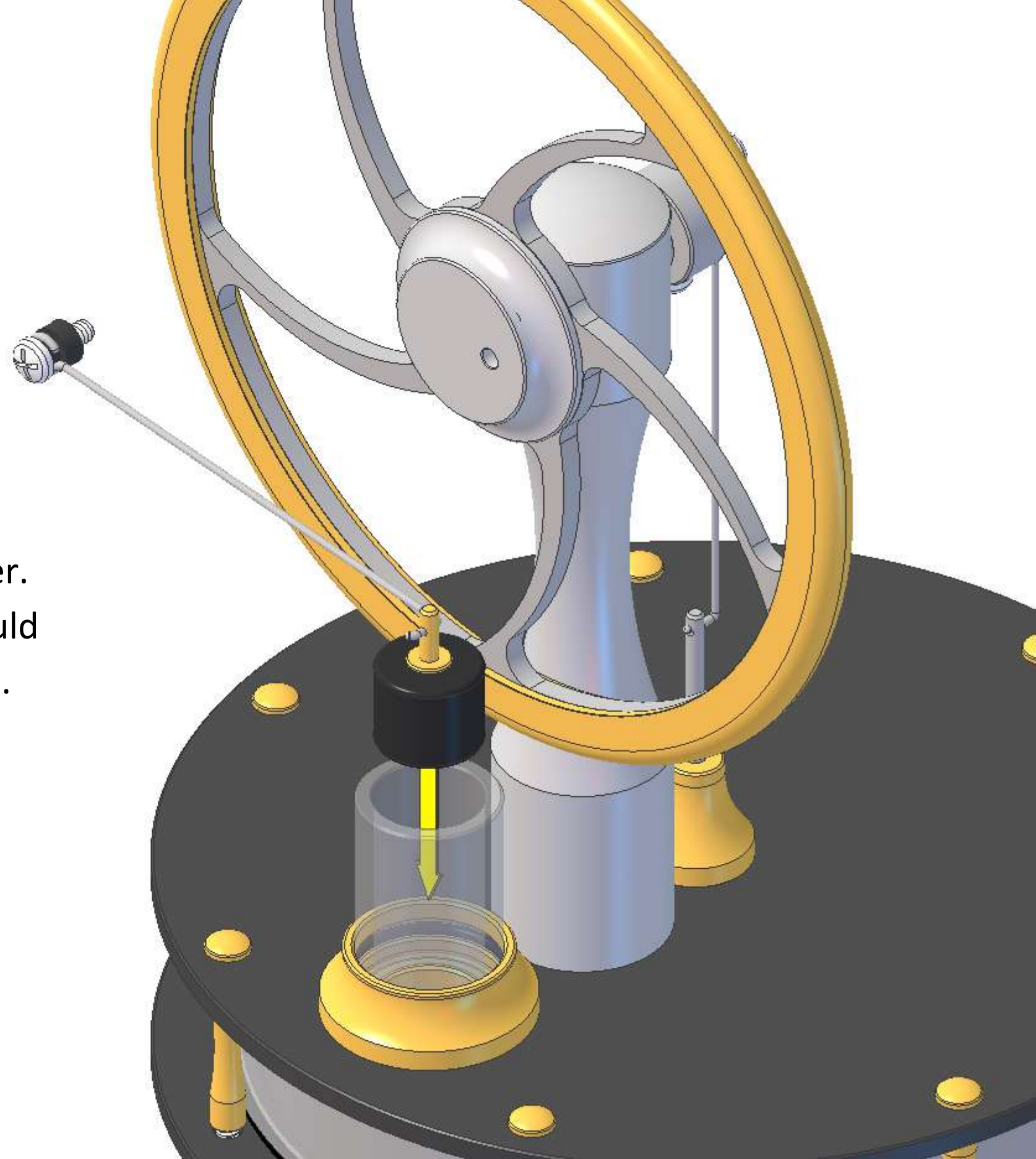

Screw the conrod screw into the hole in the front face of the hub. Tighten only sufficient to lock, over-tightening will cause the conrod bush to expand and pinch the conrod eye, which could prevent your engine from running.

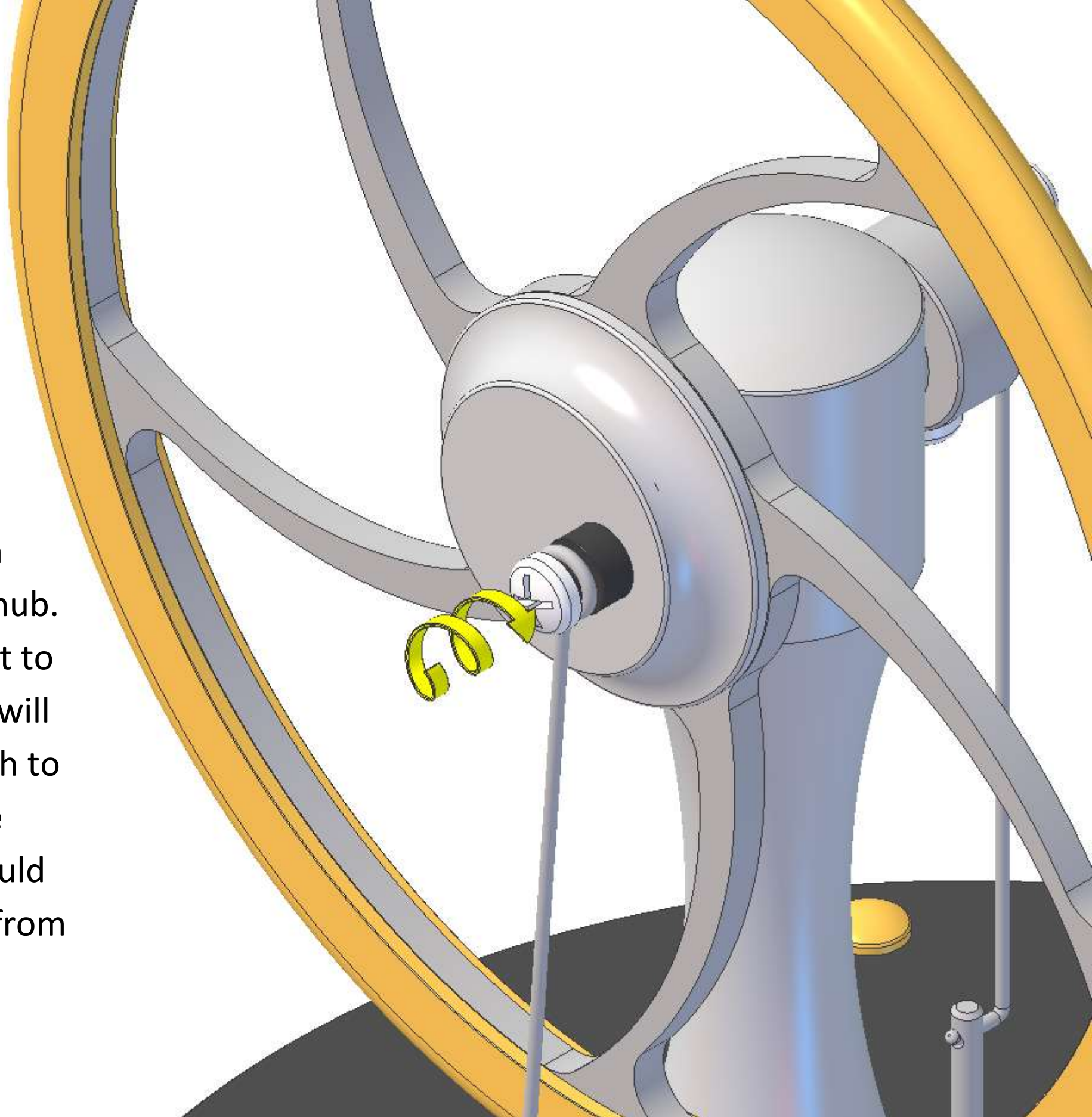

Your engine is now fully assembled.

Check that the flywheel rotates fully, a small amount of resistance will be felt on rotation due to the air pressure inside the main chamber. Check the piston does not bump into the bottom of the cylinder and re-check the displacer does not bump into either plate.

Once you have made these final checks you are ready to operate your engine.

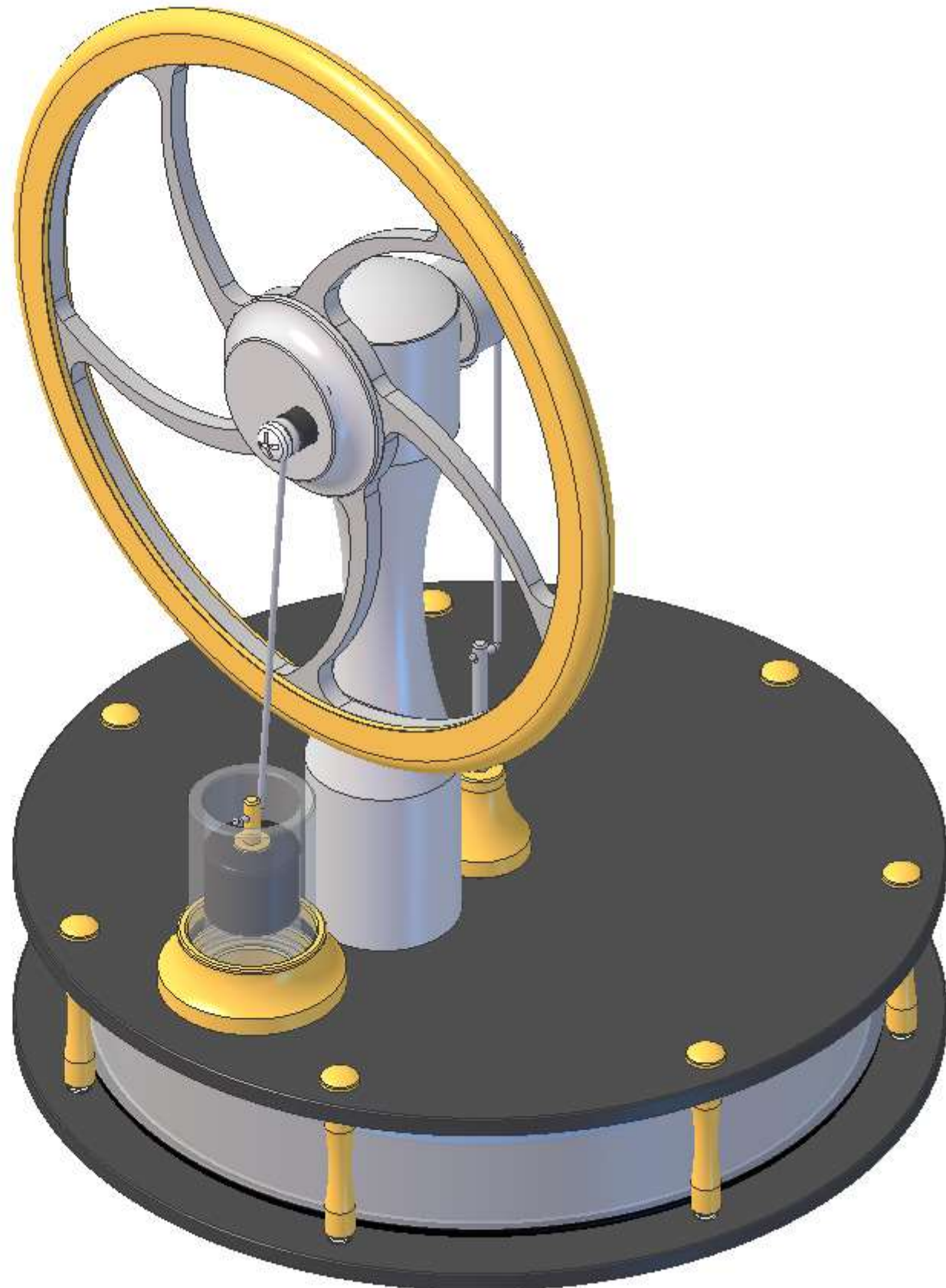

The engine is not self-starting; you will need to give the flywheel a little spin to get it going. After the engine has been on your heat source for half a minute to a minute gently spin the wheel and it should carry on running.

The engine has been designed to run on hand heat, but will run equally as well from a wide variety of heat sources, including Digital TV box, adsl modem, table lamp, hot water - tea or coffee, warm sunlight.

The engine will operate in reverse if you place it on a bowl of ice, this is because Stirling engines operate on a temperature difference, and it doesn't matter if the top plate is cool, as in conventional running, or the bottom plate is cool, as in ice running.

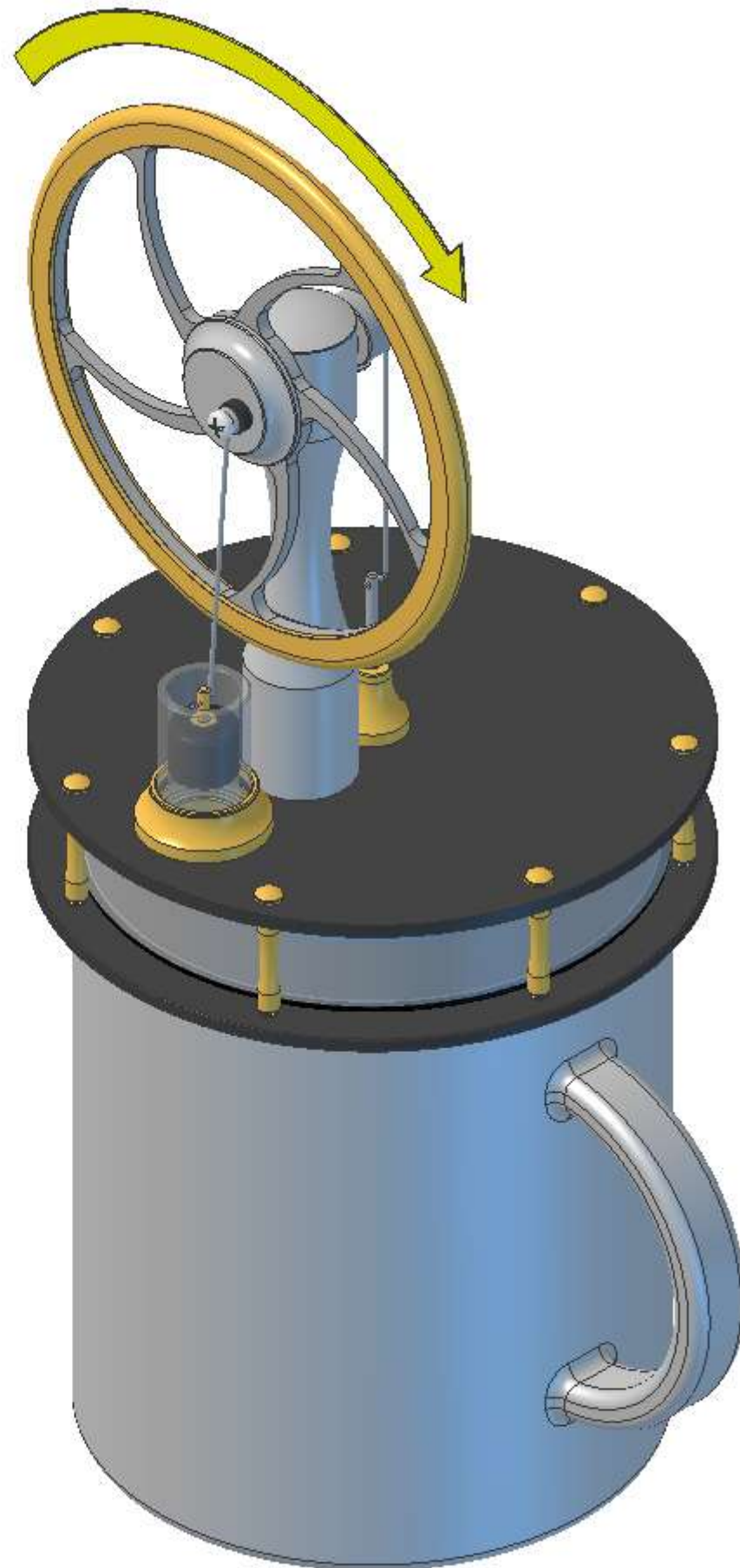

The engine only requires a very small temperature difference between the top and bottom plates to operate, anything hotter than hot water WILL damage it. DO NOT place it on any high temperature heat source (cooker, wood burning stove, candle etc.). This will melt a number of parts on the engine.

If you wish to operate your engine on hot coffee or tea you must allow the liquid to cool for a couple of minutes first.

The hottest heat source that you should use for your KS90 engine must not be hotter than 75°C (167°F).

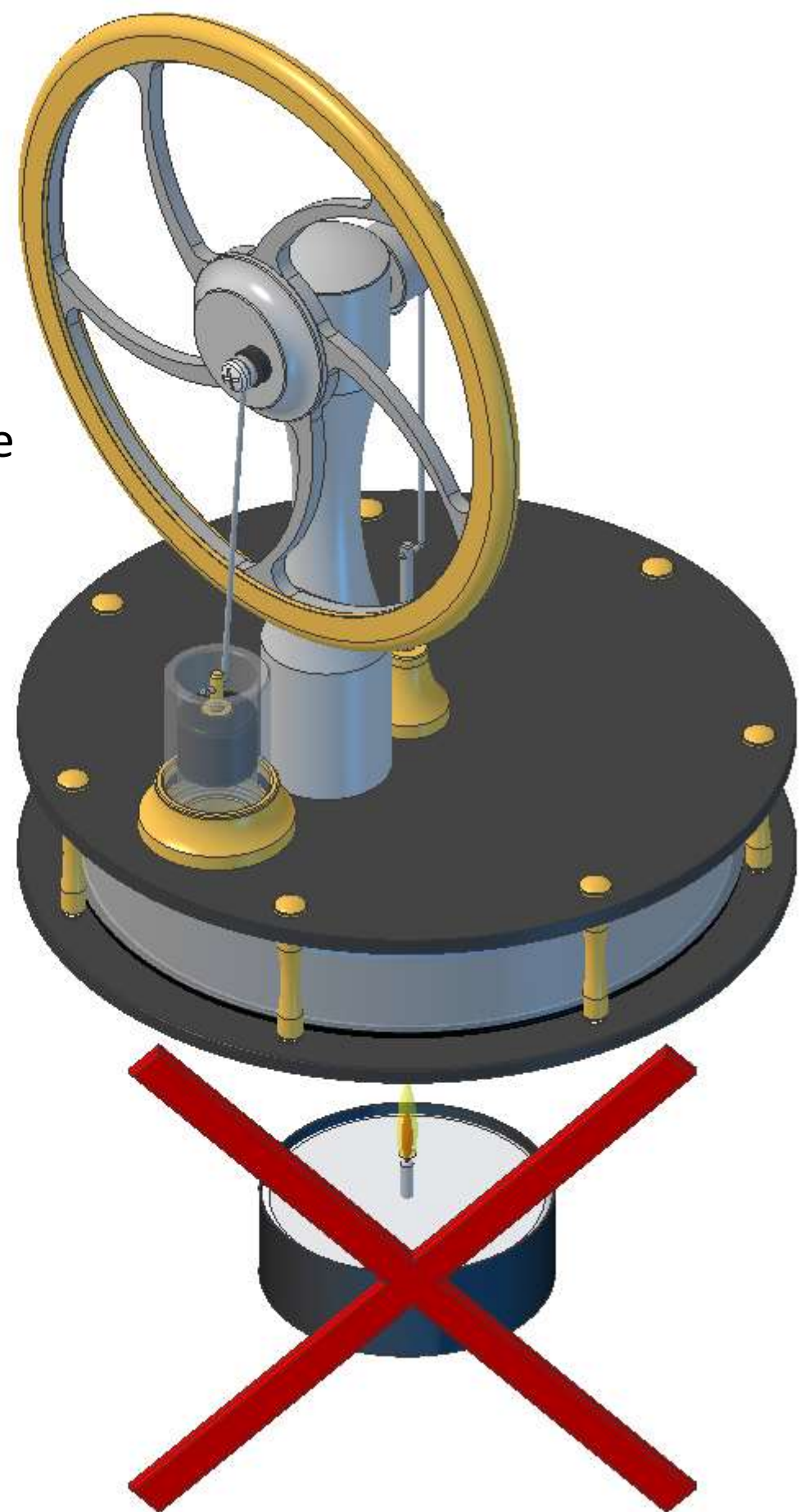

If your engine stops suddenly after a few revolutions the main axle ball-race bearings might need cleaning.

Disassemble your engine (by following the assembly instructions backwards) until you gain access to the bearings. Remove them and rinse in Methylated spirit or Denatured alcohol. Then either blow dry with compressed air or allow to dry naturally on an absorbent cloth or paper towel.

Follow the assembly instructions to reassemble your engine.

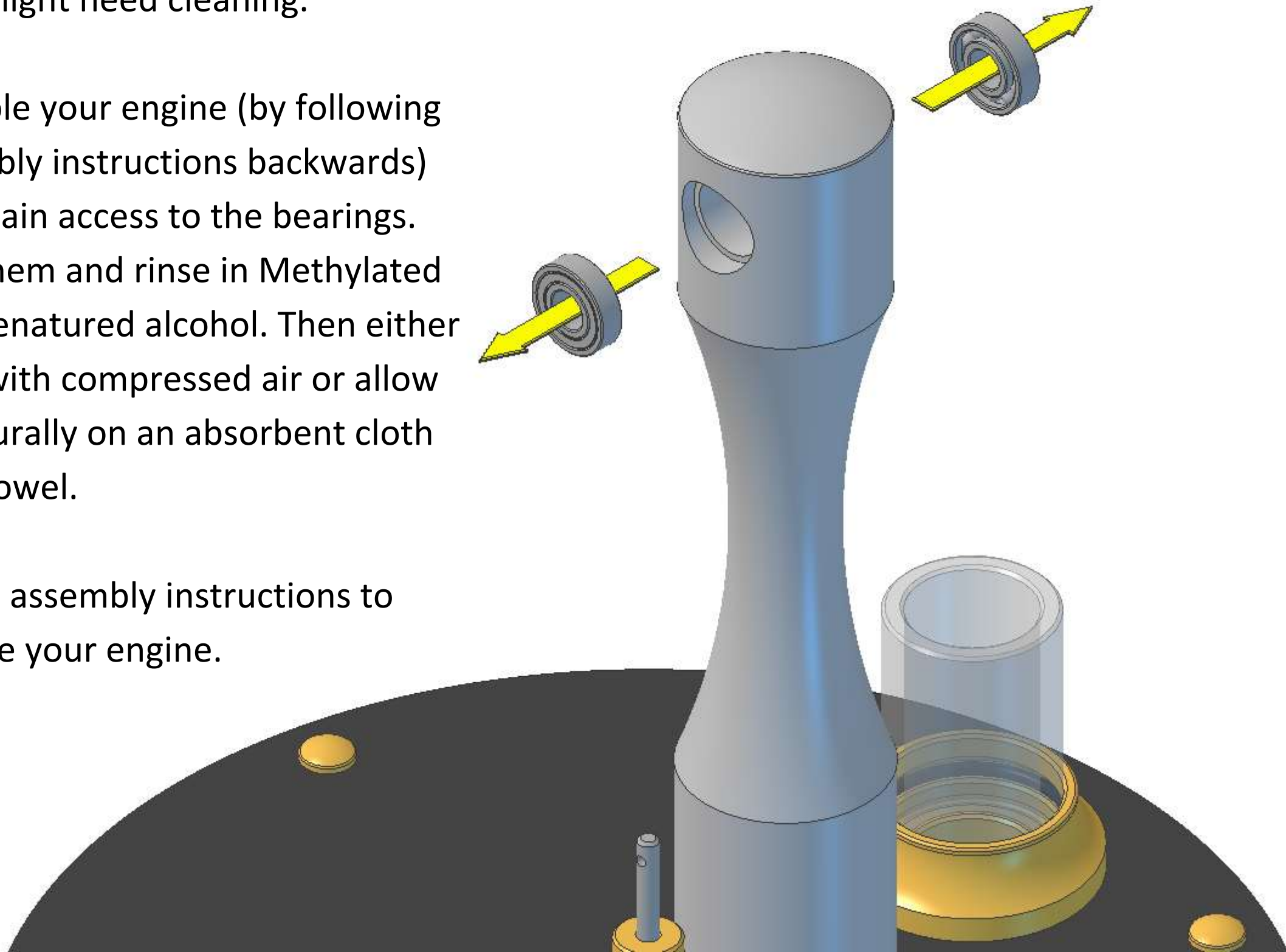

If your engine is running slower than usual you might need to clean the piston and cylinder.

Unscrew the conrod screw from the hub and slide the conrod and piston out of the cylinder.

Wipe the piston with a paper towel and clean the inside of the cylinder with a rolled up paper towel or cotton bud.

Make sure there are no stray fibres on the piston or in the cylinder and re-fit by sliding the piston into the cylinder (some air pressure will be felt, this is normal) and screwing the conrod screw into the hole in the face of the hub.

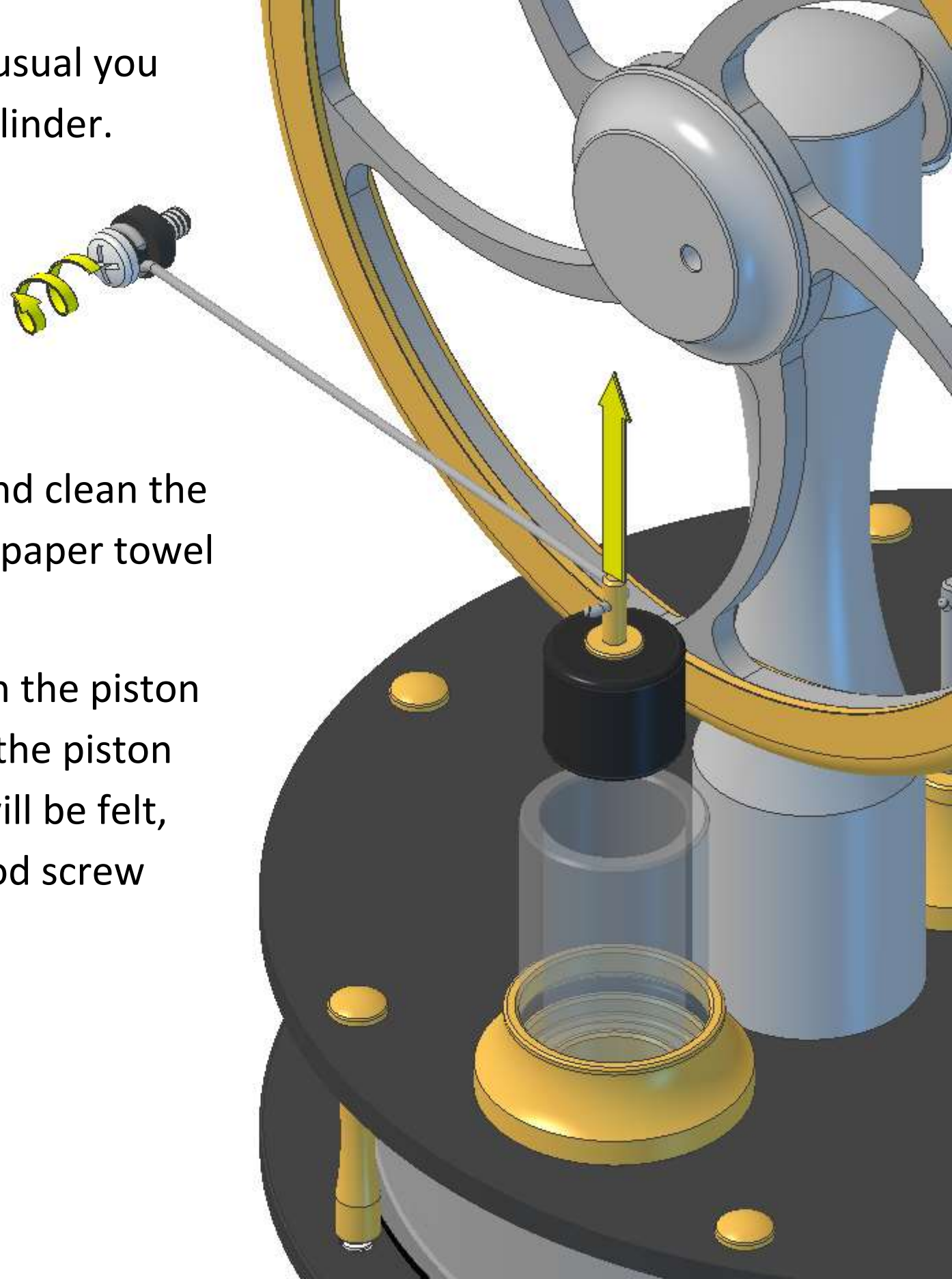

If your engine is running slower than usual you might need to clean the gland stem.

Rotate the flywheel until the displacer stem is at its highest point, and wipe the stem with a cloth.

Make sure there are no stray fibres from your cloth left on the stem.

